

Create your own unique look
for any living space



RP-1266



RP-1273

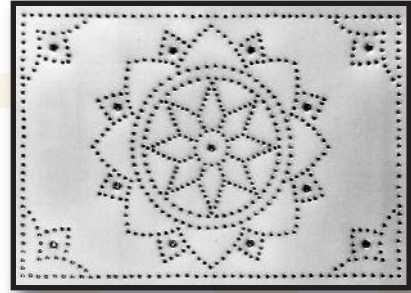

RP-1005

Pierced Tin Designs, LLC
by Country Accents

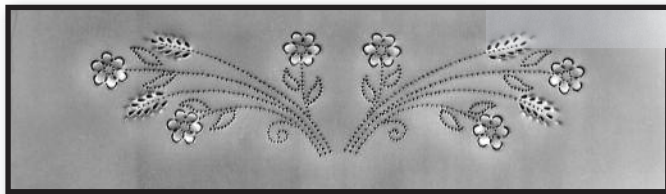

RPA-1042



RP-1176



RP-1068

*For any style and any
living space, create it
in your own way*

Traditional,
modern,
geometric.

Whatever your style!



RP-1212



RP-1138

We can even create custom sizes and custom designs for you!

Custom sizing and designs of pierced metal panels is our specialty. The founder and artist of over 30 years developed most of our designs, some exclusive to Country Accents®. As designers and makers of museum quality panels, we often match designs and finishes of "old," and almost forgotten, punched tin panels.

Our specialties include:

- ability to create unusual pieces and artistic designs
- will design to suit
- widest choice of metal finishes
- historically accurate
- ability to fulfill complex or large orders

Pierced Tin Designs, LLC
by Country Accents

615 Dunwoody Road, Williamsport, PA 17701

Email us! sales@piercedtin.com

Call us! 570-478-4127 (Mon-Fri 9-5 EST)

Fax us! 570-478-2007 (24 hours a day!)

Our website: www.piercedtin.com



RP-1244
"Daisy in Oval"

Fruits of the Vine



10 x 32 (shown)

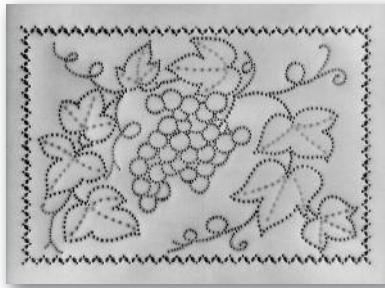

RP-1212

shown: 14 x 10
10 x 14



RP-1212

shown: 16 x 24
10 x 24
12 x 24

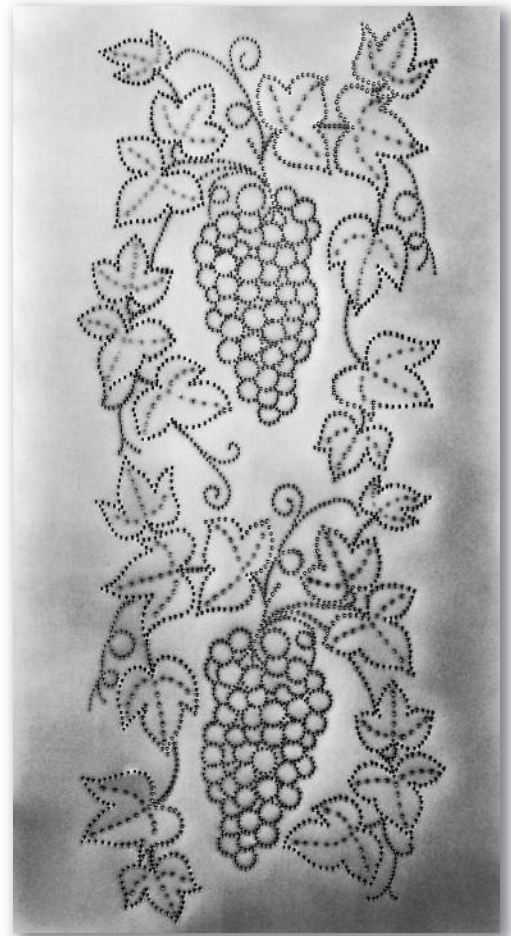

RP-1212

20 x 36

RP-1212 shown above with double image.
Please specify with or without border.



Vol. 1, No. 13

2013

TABLE OF CONTENTS

Ready Punch™ Panel designs.....	1-33
Custom Sizes/Custom Designs.....	38, 40
Adapting pierced panels for appliance fronts.....	34-35
Customize with borders	36
Self-edged, front-mounting panels	37
Drawer fronts panels.....	37
Measuring/Ordering Information	38
Mounting/Installation Instructions.....	39
Frequently Asked Questions	38
Care of your finished panels	39
Finishes, Samples & Color Chart	Inside back cover
Price List (for standard panels*).....	Enclosed brochure
Order Blanks	Enclosed brochure

* Special sizes other than the ones listed in catalog pages and price list **must be specially quoted**. Please call us with the information as outlined on page 38.

Designs pictured here, as they appear or modified, or sold as patterns, finished goods, or in kits are the property of Country Accents®, and are copyright protected. They are intended for use in craft projects by individuals. The unauthorized copying or modification of these designs by any means for the purpose of distribution or resale is expressly forbidden. Fraudulent use of these designs either as shown or modified will be prosecuted to the full extent of the law.
All Rights Reserved © 2013.

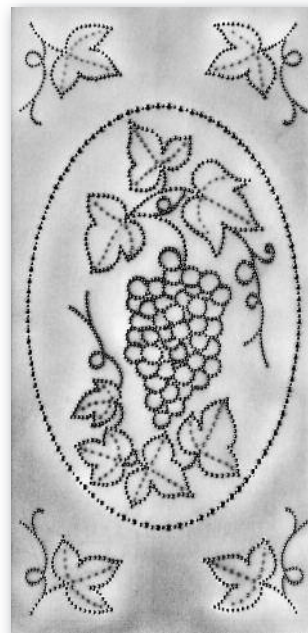

RP-1247-A

shown: 12 x 24
10 x 14

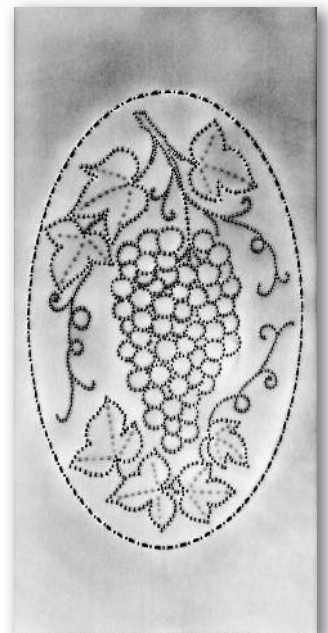

RP-1247

shown: 12 x 24
10 x 14

Harvest Wheat

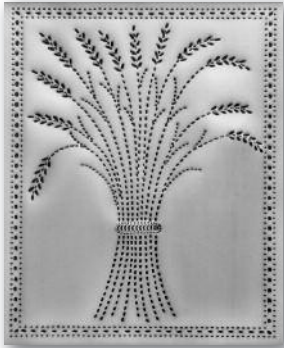

RP-1169 *shown:* 14 x 18
10 x 14
12 x 24
14 x 10

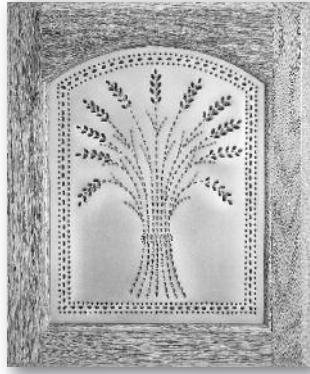

RP-1169 Customized
(sold unframed)

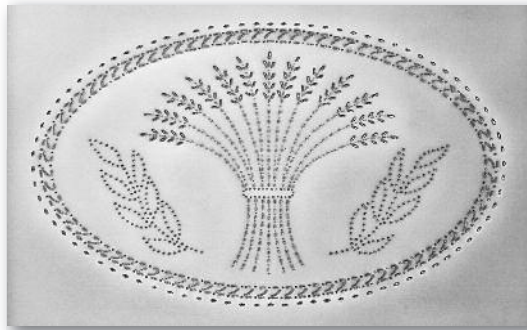

RP-1176 H 22 x 12



RP-1176 10 x 14
14 x 10
12 x 24
shown: 13 x 20



RP-1176 Customized

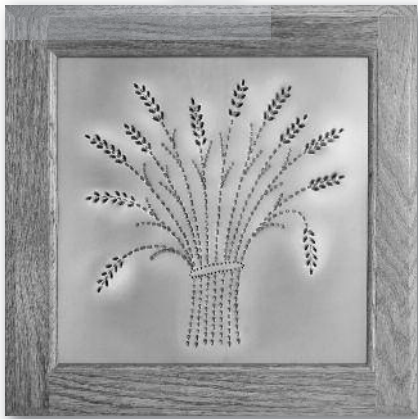

RP-1250 12 x 12, 10 x 10
(sold unframed)

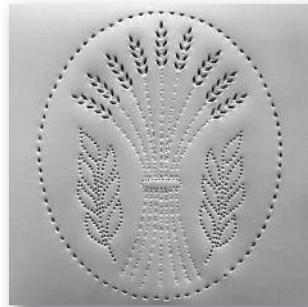

RPS-1176 A
*Many sizes available!
Please call!*

Acorns and Oak Leaves

The panels shown here provide an example of how your favorite design can be customized and adapted to different sizes, illustrating how all the various panels for your project can "match" regardless of size and proportion.

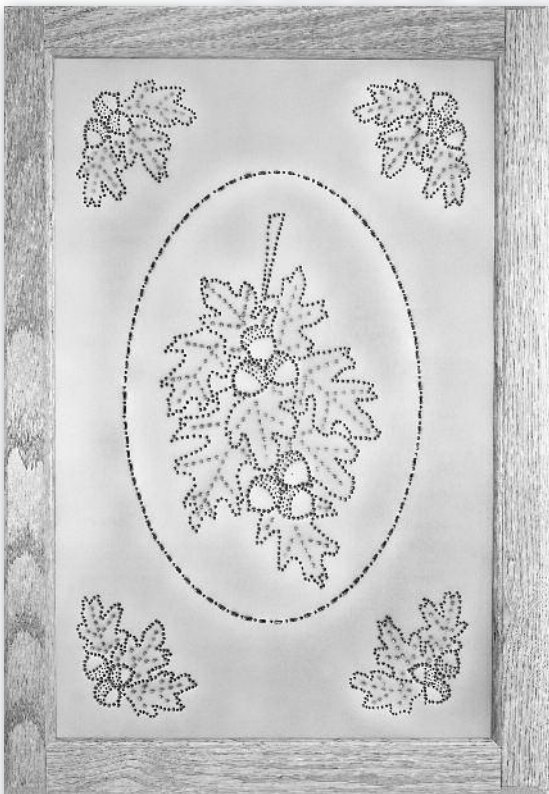

RP-1129 Customized



RP-1129/R 10 x 14
shown: 12 x 24



RP-1129 Customized

Wheat Flowers

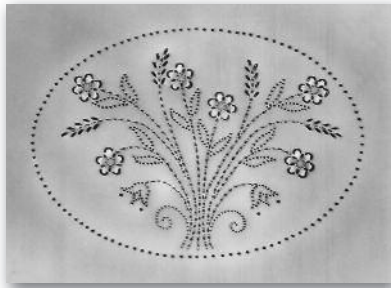

RP-1108 shown: 14 x 10
10 x 10



RP-1042 shown: 12 x 24
10 x 14



RP-1042A shown: 10 x 14
12 x 24



RP-1042B shown: 10 x 14
12 x 24

Please note:
All Wheat Flower Designs
are available in left facing,
right facing or straight.
Please specify quantity of
each when ordering.

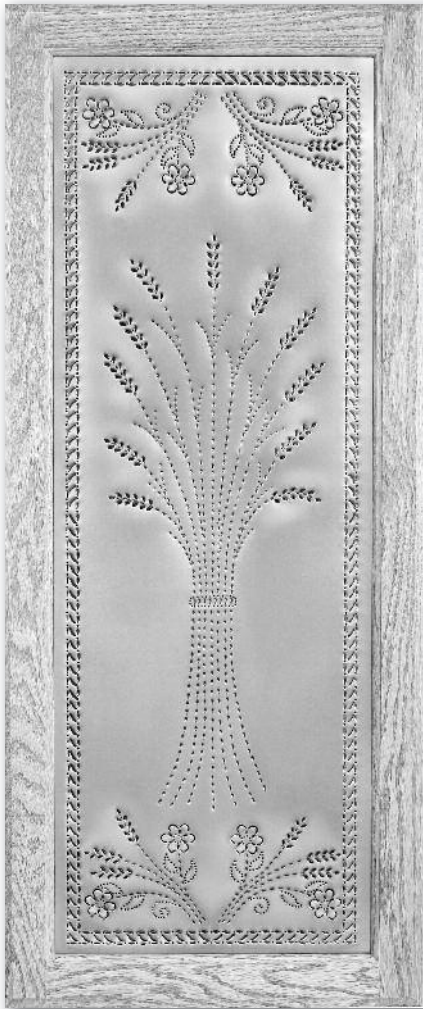

RP-1286 13½ x 37½

Combining images...

Many times, we are requested to
combine images from one design with
another, creating a unique panel!

At left, panel RP-1286 features:
Wheat from RP-1169,
wheat flowers from RPA-1042,
and Custom Border B004!

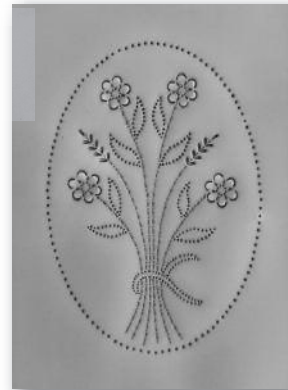

RP-1042C 10 x 14

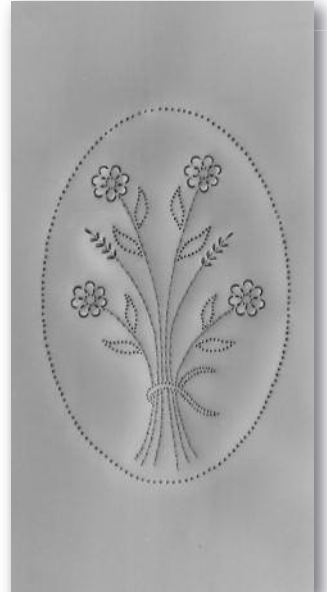

RP-1042C 12 x 24

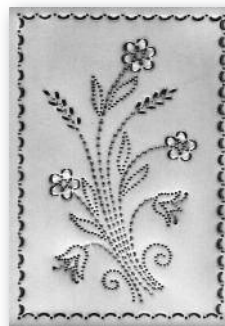

RP-1195 8 x 11

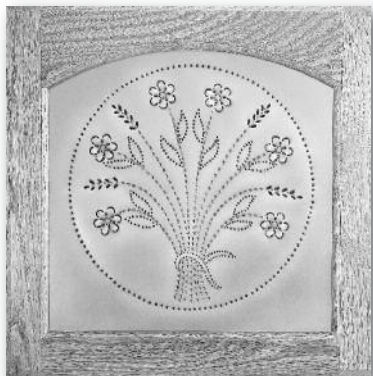

RP-1042/SQU Customized
(sold unframed)

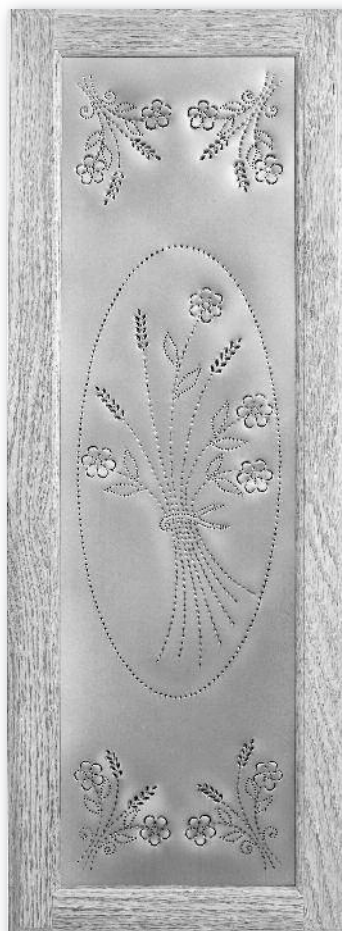

RP-1042 Customized
(sold unframed)

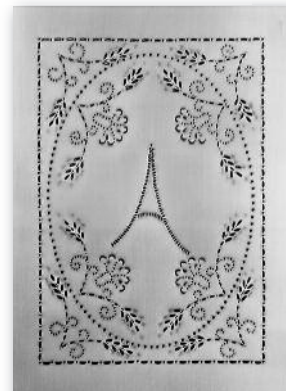

RP-1045 10 x 14



RP-1045 12 x 24

Personalize
your panels with your
very own initial!

Fanciful Fruit

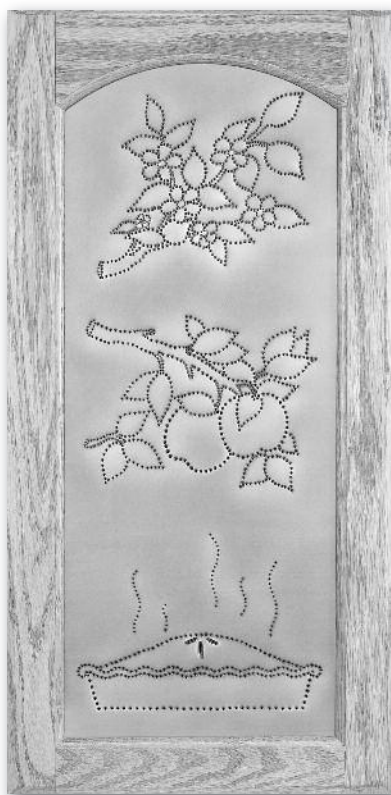

RP-1259-A 11 x 26
featuring *Apple Blossoms & Apples*
(sold unframed)

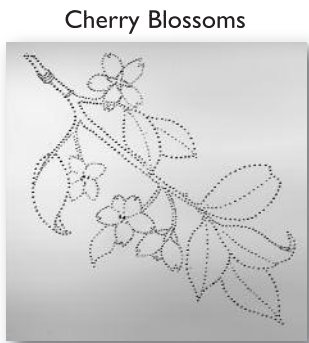

Cherry Blossoms

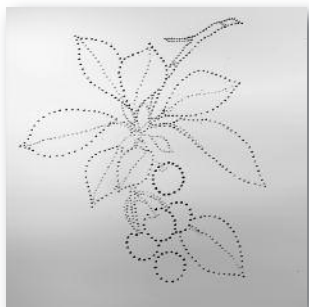

Cherries

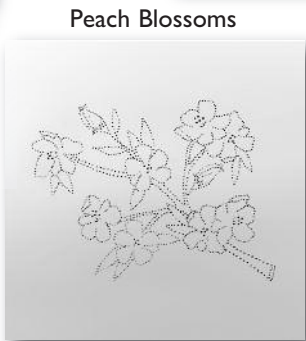

Peach Blossoms

Peach

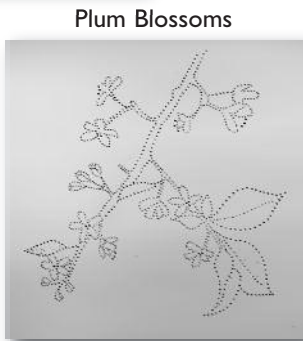

Plum Blossoms

Plum

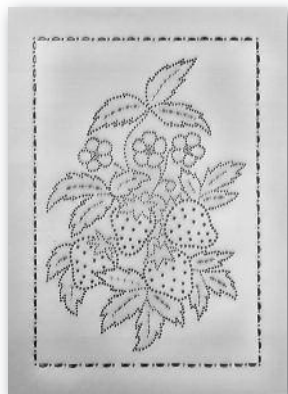
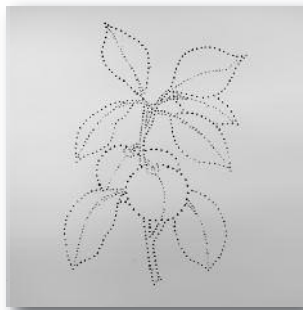
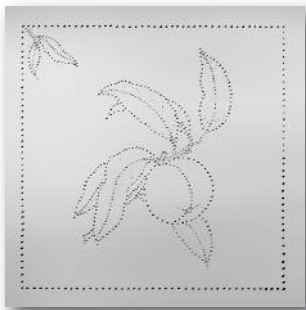

RP-1125 shown: 10 x 14
12 x 24

Any of our fruit designs can be customized into a valance!

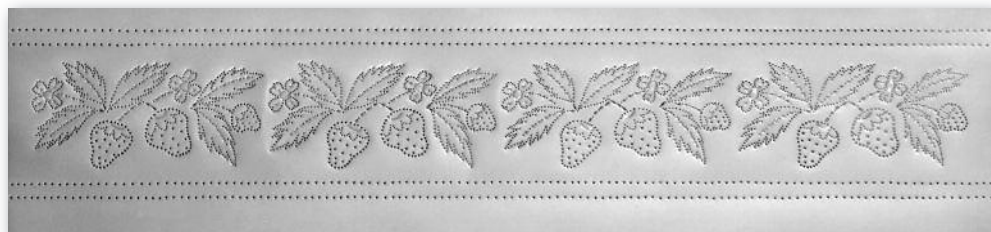

RP-1097 36 x 8

Fresh baked comfort...

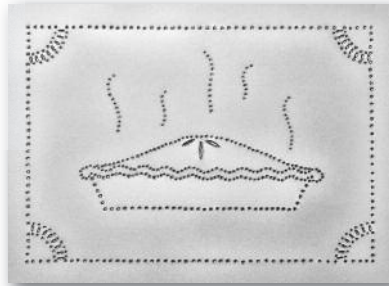

RP-1234 shown: 14 x 10
12 x 10, 10 x 10, 10 x 14

Warm apples...

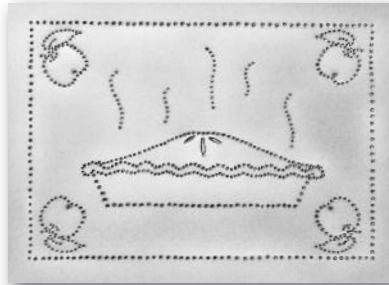

RP-1234-A (same sizes as above)

Juicy Cherries...

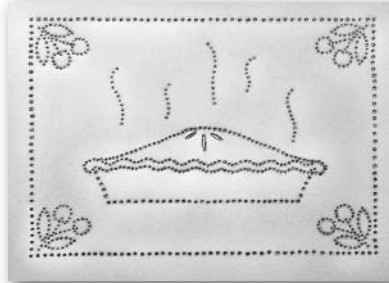

RP-1234-C (same sizes as above)

Luscious Peaches...

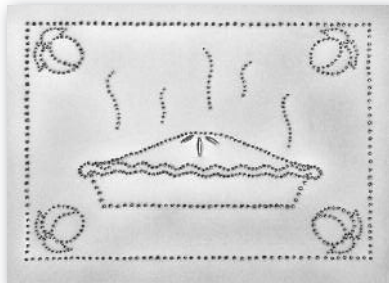

RP-1234-B (same sizes as above)

Succulent Plums...

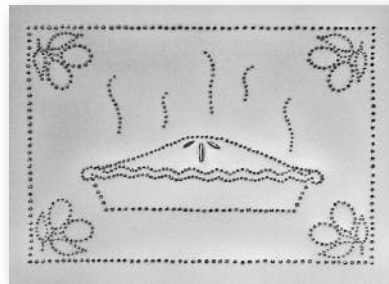

RP-1234-D (same sizes as above)

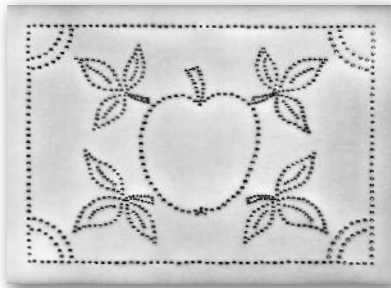

RP-1240 *shown:* 14 x 10
12 x 10

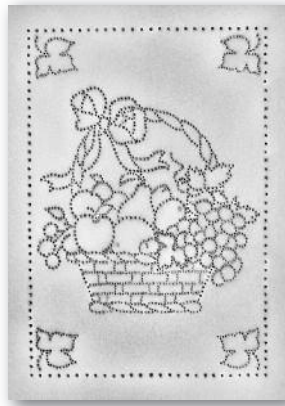

RP-1263 10 x 14

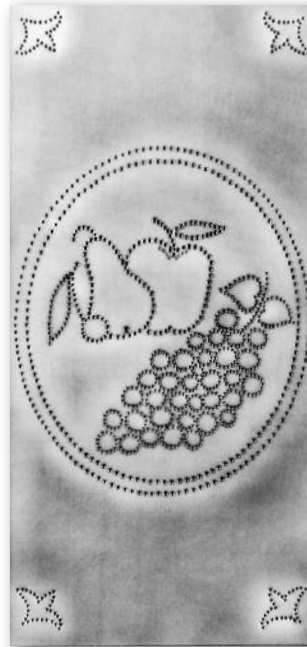

RP-1214 *shown:* 12 x 24
10 x 14
10 x 24
12 x 10

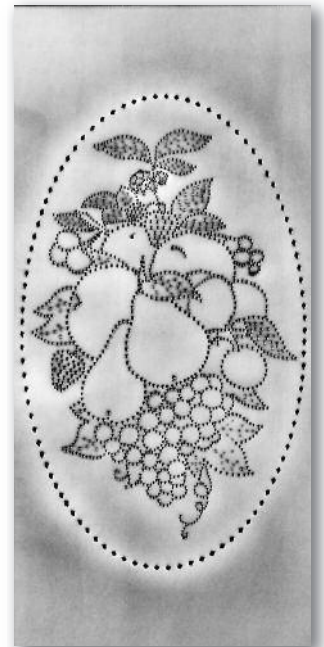

RP-1248 12 x 24



RP-1240-A *shown:* 14 x 10
12 x 10

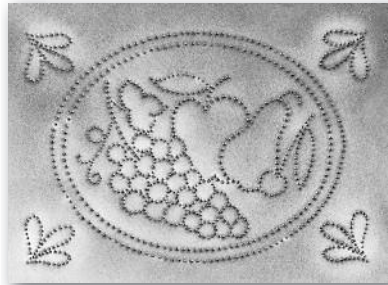

RP-1214 *shown:* 14 x 10
10 x 12, 10 x 14

Welcoming Pineapples...

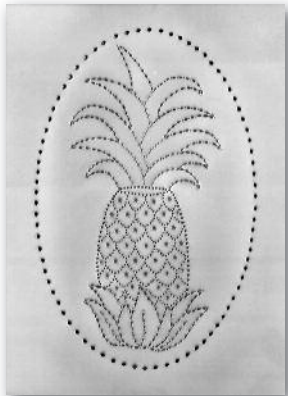

RP-1095/R *shown:* 10 x 14
12 x 24

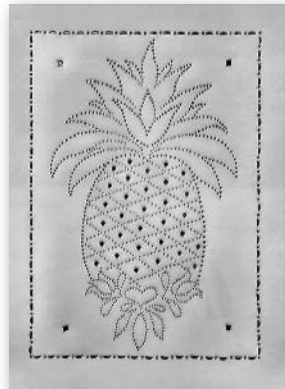

RP-1081 10 x 14

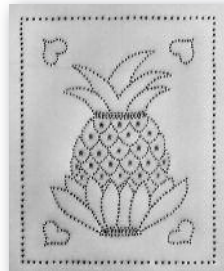

RP-1083/R 8 x 10

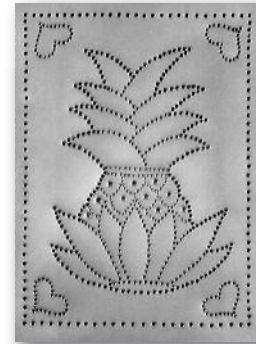

RP-1082/L 9 x 12



RP-1075/L 9 x 12

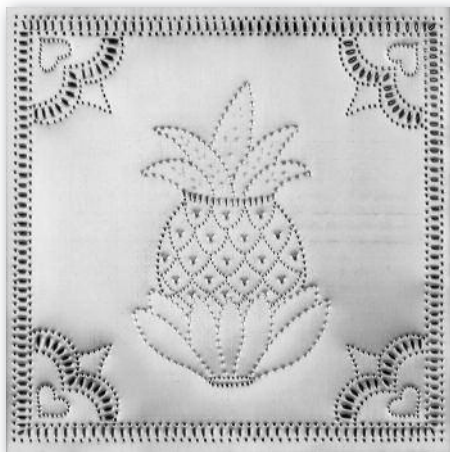

RP-1054 *shown:* 10 x 14
16 x 16

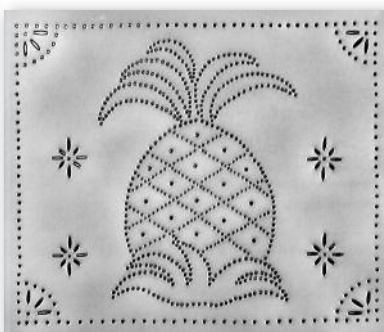

RP-1077/R *shown:* 14 x 12
14 x 10

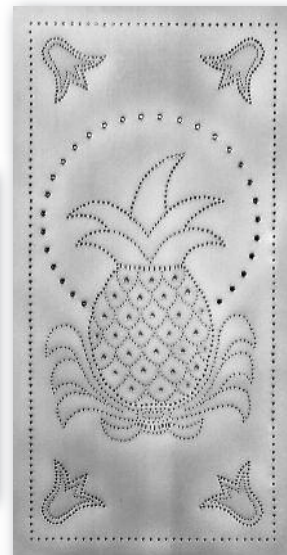

RP-1063/L 10 x 18
shown: 12 x 24



RP-1029/R 12 x 24

Nautical Images

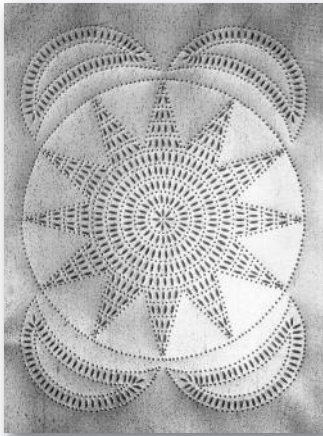

RP-1128 14 x 20



RP-1180 12 x 16

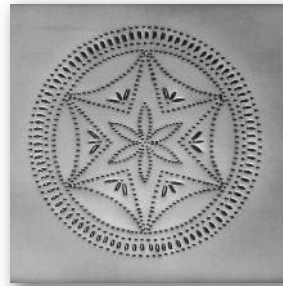

RP-1202 10 x 10

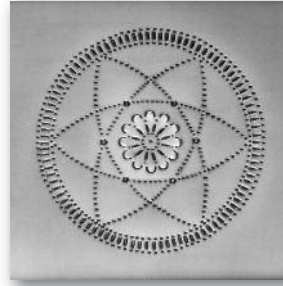

RP-1200 10 x 10



RP-1264 14 x 32
(sold unframed)

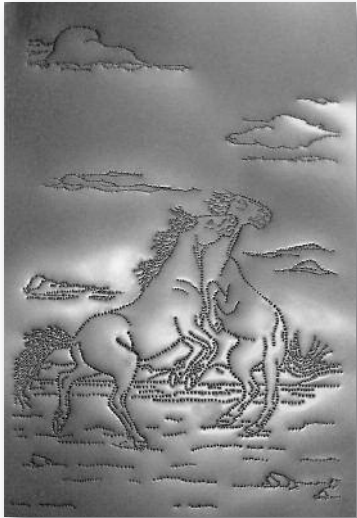

"Wild Horses" Customized

Southwest Inspired

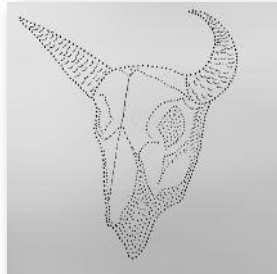

"Steer Head" Customized

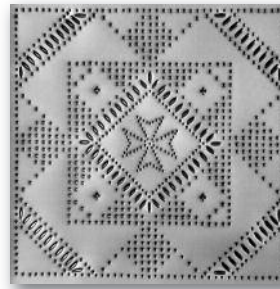

RP-1185 12 x 12

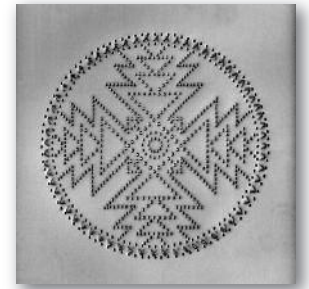

RP-1184 10 x 10

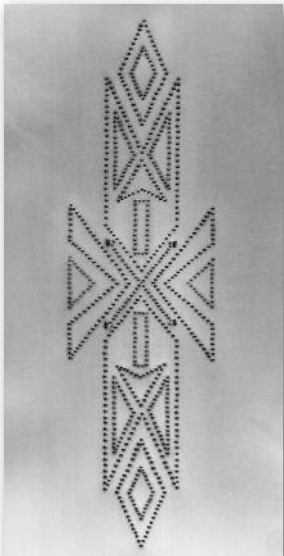

RP-1187 10 x 24



RP-1179 14 x 20

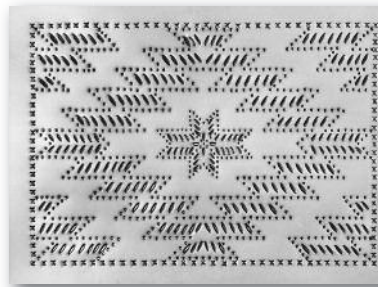

RP-1177 14 x 10

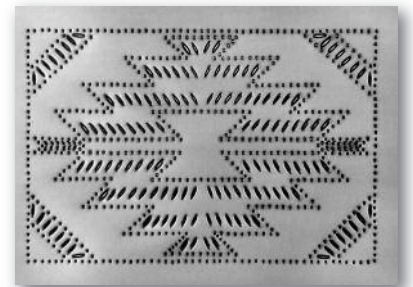

RP-1186 14 x 10

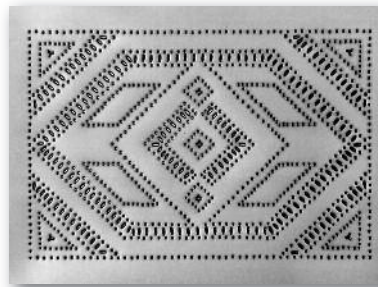

RP-1178 14 x 10

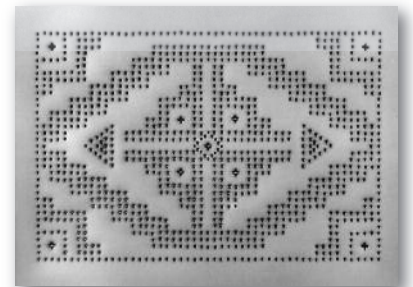

RP-1175 14 x 10

Ornamental Designs



RP-1283 8 x 16



RP-1268 9 x 22



RP-1281 8 x 20



RP-1285 8 x 16



RP-1267 9 x 22



RP-1284 8 x 16

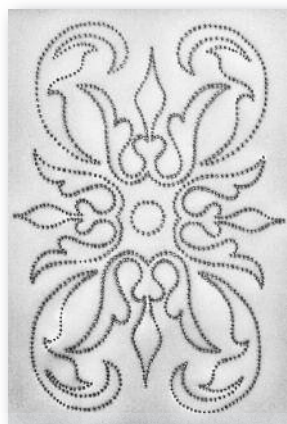

RP-1282 10 x 14

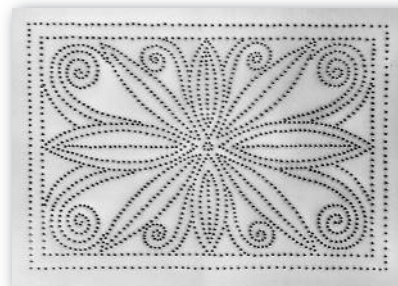

RP-1073 14 x 10

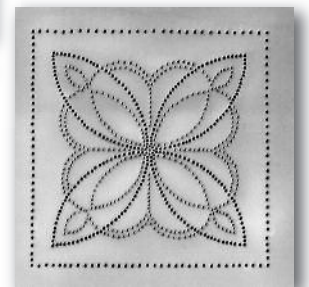

RP-1069 10 x 10

Many designs throughout the catalog can be used horizontally or vertically



RP-1277 12 x 31

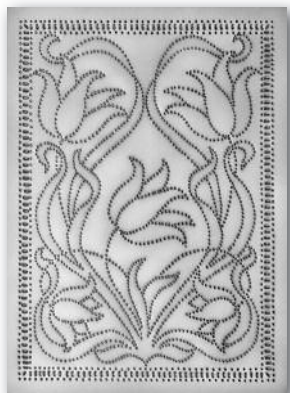

RP-1254 10 x 14



RP-1269 10 x 14

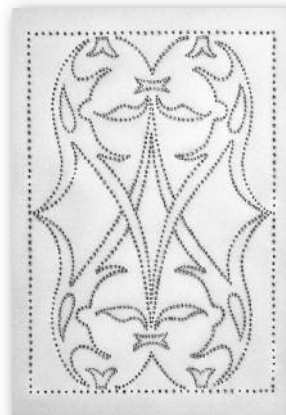

RP-1276 10 x 14

Early Pie Safe Motifs

These familiar pierced tin designs are based on some of the earliest examples of the craft found in many private and museum collections. These motifs should be used where unquestioned authenticity is required.

The circle, quarter circle, and half circle, as well as the diamond motifs were very common to pierced metal during the early years of this country's settlement. Found on both Revere-type lanterns and food safe panels, this design, both alone and in combination, lends an air of authenticity to today's applications.

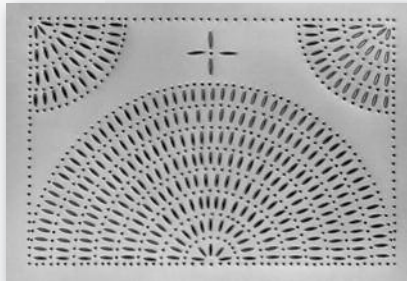

RP-1087

14 x 10

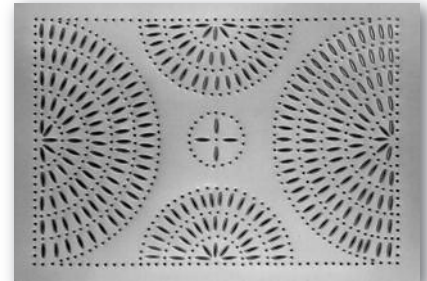

RP-1088

shown: 14 x 10
12 x 24

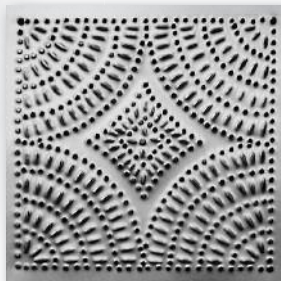

RP-1007

shown: 10 x 10
10 x 20

Featuring RP-1088 (4-way Sunrise), customized

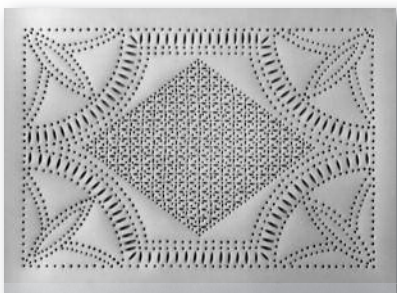

RP-1155

14 x 10

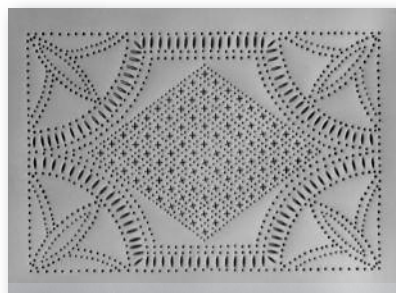

RP-1155A

14 x 10

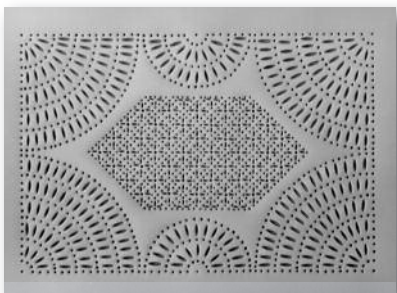

RP-1156

14 x 10

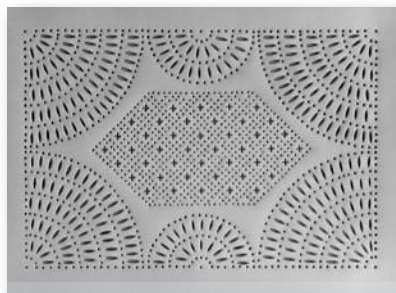

RP-1156A

14 x 10

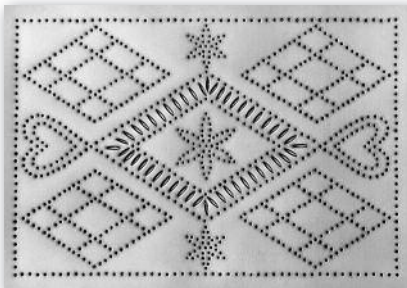

RP-1142 14 x 10

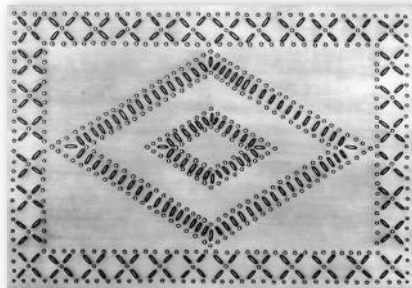

RP-1009 shown: 14 x 10
12 x 24

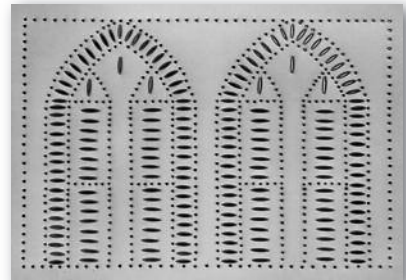

RP-1107 14 x 10

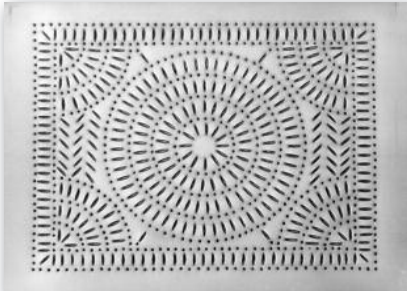

RP-1135 14 x 10

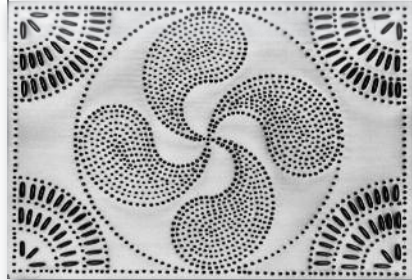

RP-1027 14 x 10

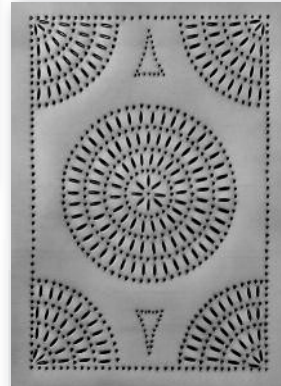

RP-1057 shown: 10 x 14
11 x 14
12 x 24

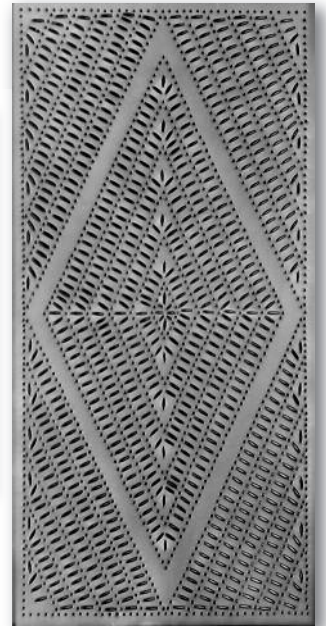

RP-1003 10 x 14
shown: 12 x 24

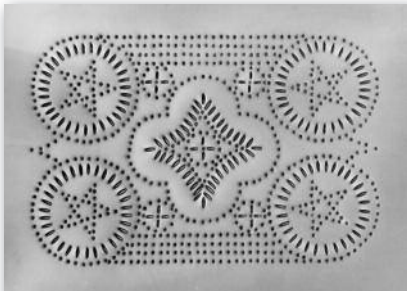

RP-1130A 14 x 10

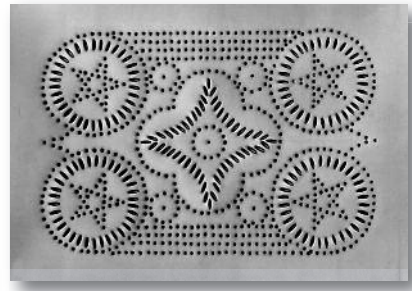

RP-1130 14 x 10

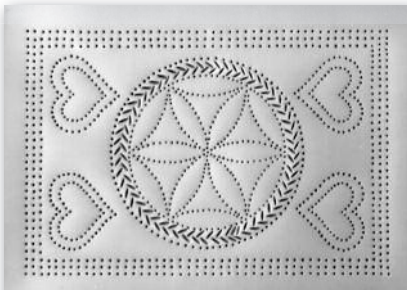

RP-1153 14 x 10

Many designs throughout the catalog can be used horizontally or vertically

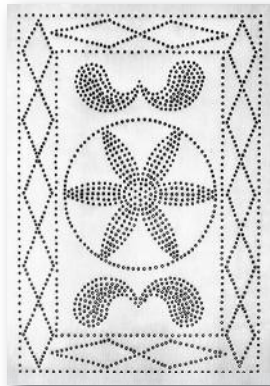

RP-1014 10 x 14

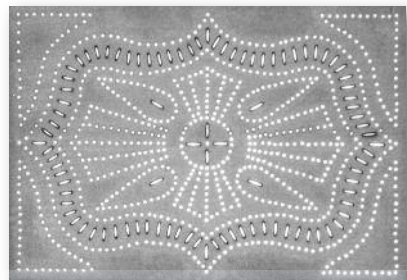

RP-1010 14 x 10



This circa 1730 house* displays panels made for the kitchen cabinets highlighting styles RP-1107A (Cathedral Window), RP-1003 (Cut Diamond), and RP-1057 (Sunburst).
*Featured in Country Living magazine, March 1985

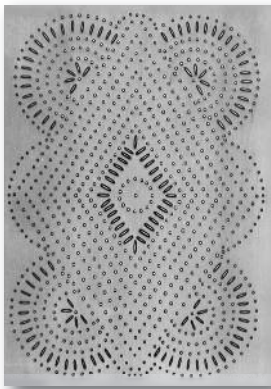

RP-1018 10 x 14

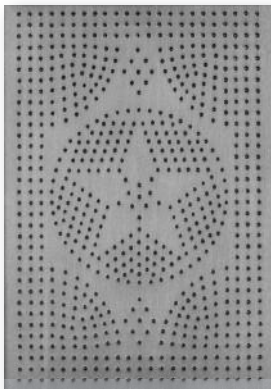

RP-1020 10 x 14

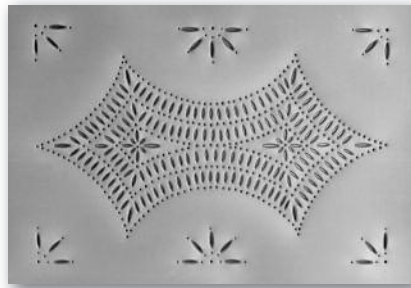

RP-1146 *shown:* 14 x 10
15 x 18

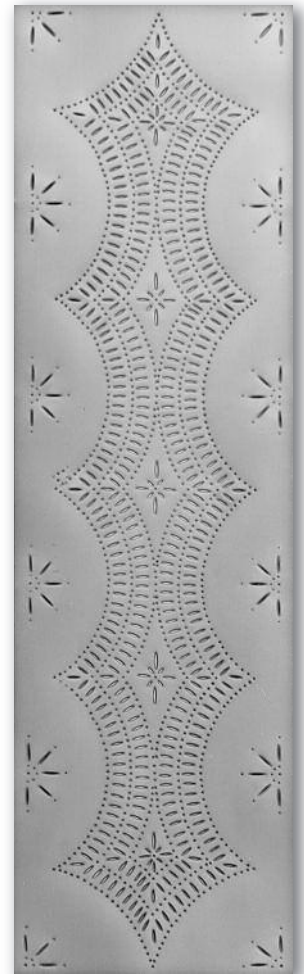

RP-1146 10 x 32

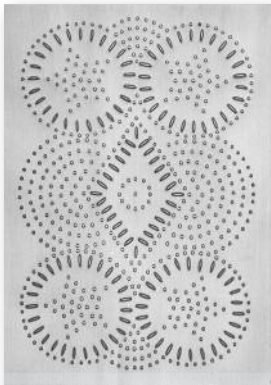

RP-1019 10 x 14

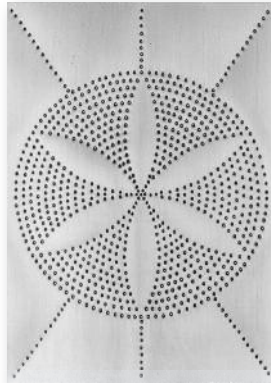

RP-1026 *shown:* 10 x 14
10 x 10

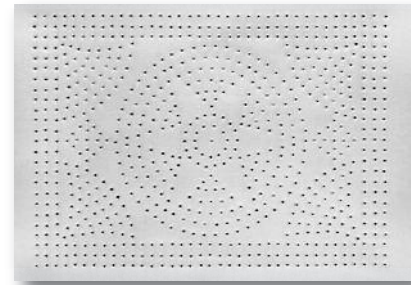

RP-1079 14 x 10

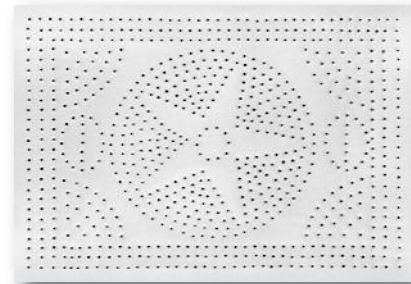

RP-1078 14 x 10



Pie safe features RP-1046

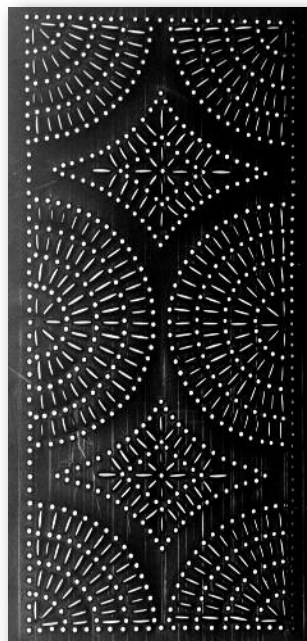

RP-1046 8½ x 18
7½ x 18

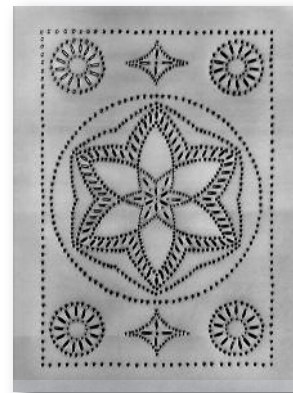

RP-1052 10 x 14

Many designs throughout the catalog can be used horizontally or vertically



RP-1060 10 x 14

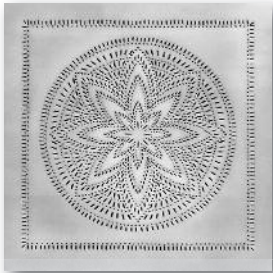

RP-1096 16 x 16

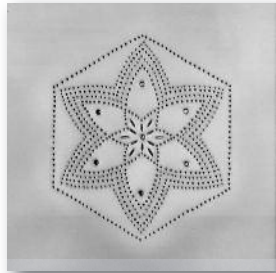

RP-1084 12 x 12

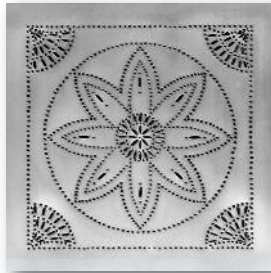

RP-1056 12 x 12

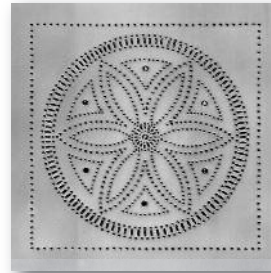

RP-1074 12 x 12

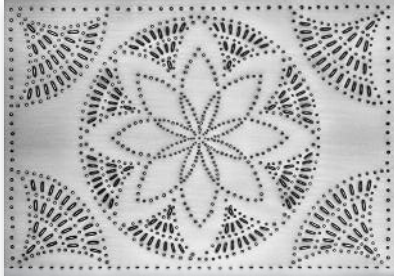

RP-1004 8 x 16
10 x 14
12 x 24
shown: 14 x 10

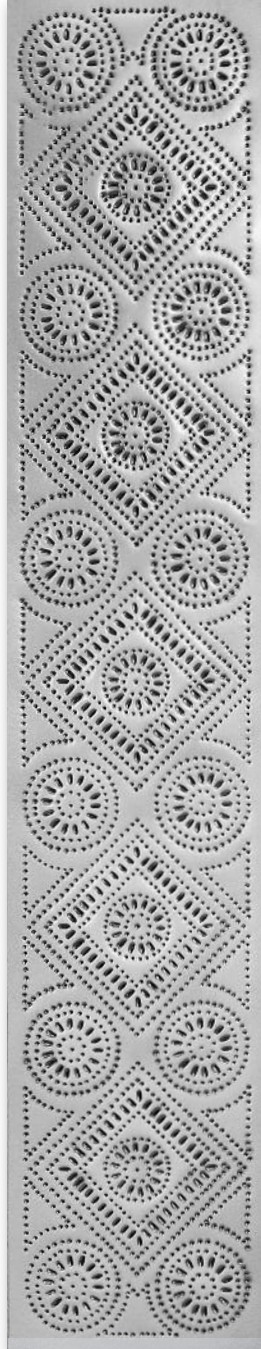

RP-1017 Custom size

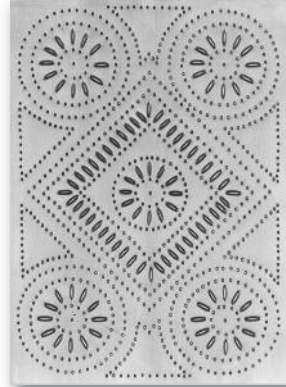

RP-1017 10 x 14

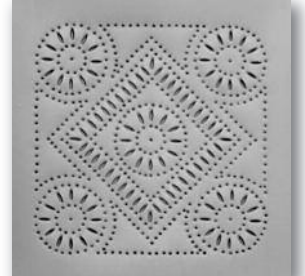

RP-1017A 10 x 10

These samples of RP-1017 illustrate how a geometric pattern may appear in repeated form.

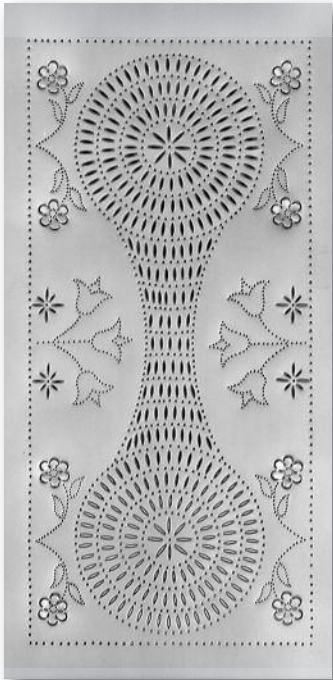

RP-1086 12 x 24

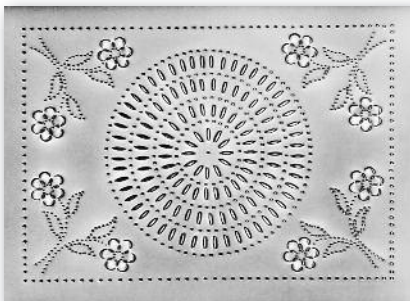

RP-1236 *shown: 14 x 10*
10 x 14



Timeless Treasures

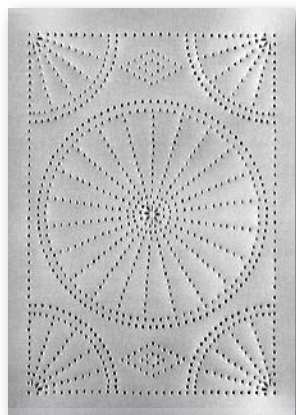

RP-1001 10 x 10
shown: 10 x 14
12 x 24

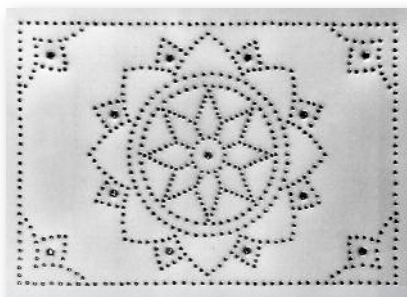

RP-1005 10 x 10
10 x 14
shown: 14 x 10

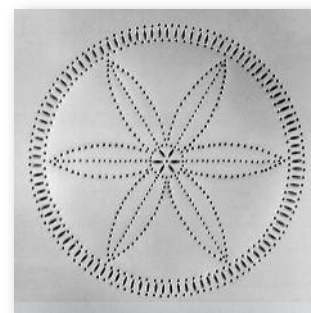

RP-1048 12 x 12

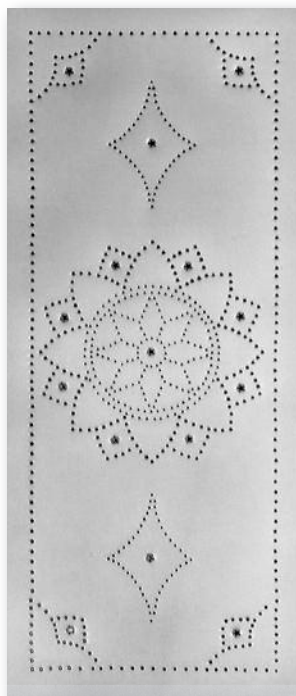

RP-1005 8 1/2 x 20
shown: 12 x 24

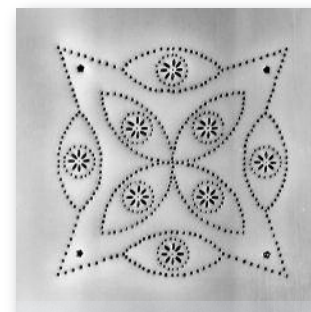

RP-1055 12 x 12

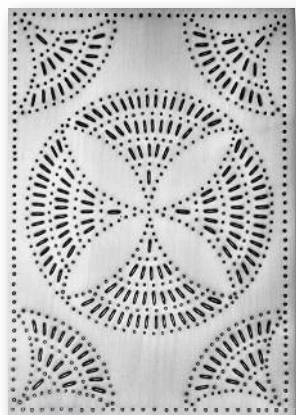

RP-1002 8 x 14
shown: 10 x 14
12 x 24

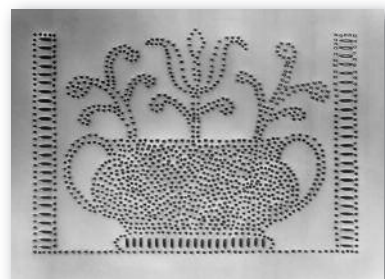

RP-1016 14 x 10

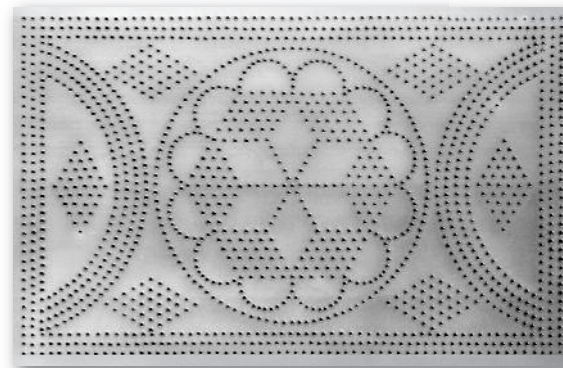

RP-1109 15 x 23

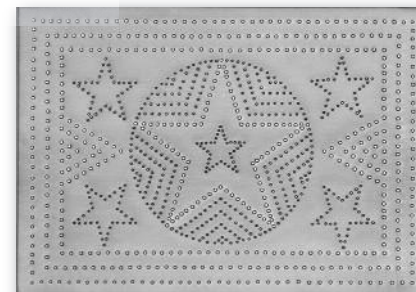

RP-1011 10 x 14
12 x 24
shown: 14 x 10

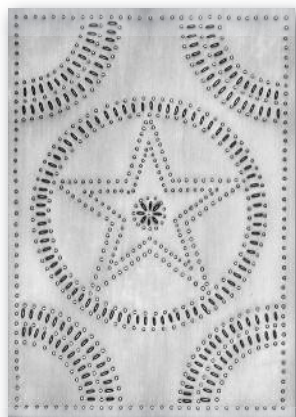

RP-1013 10 x 10
shown: 10 x 14
12 x 24
14 x 10

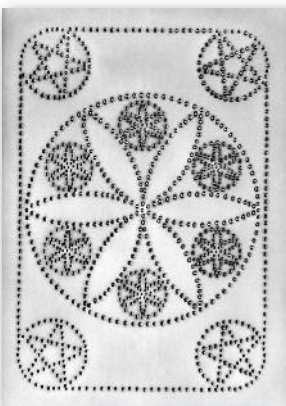

RP-1228 10 x 14



RP-1059 10 x 14

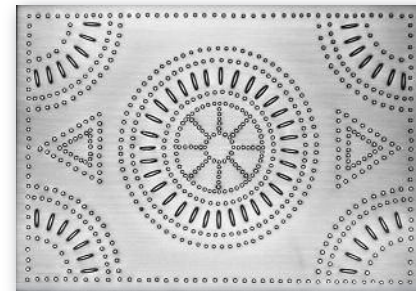

RP-1008 10 x 14
shown: 14 x 10
12 x 24



RP-1242 12 x 12
10 x 10

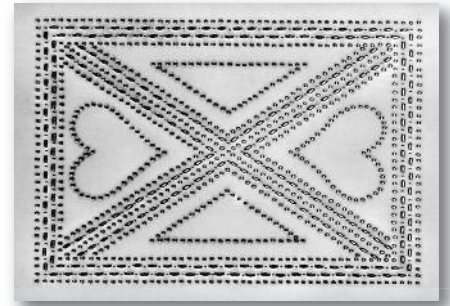

RP-1230 14 x 10



RP-1222 12 x 12

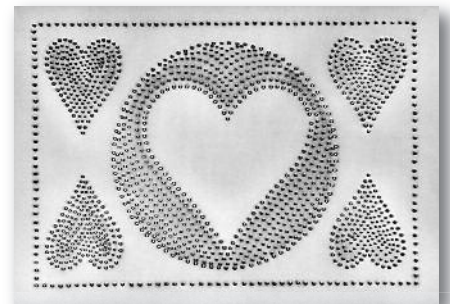

RP-1229 14 x 10

Many designs throughout the catalog can be used horizontally or vertically

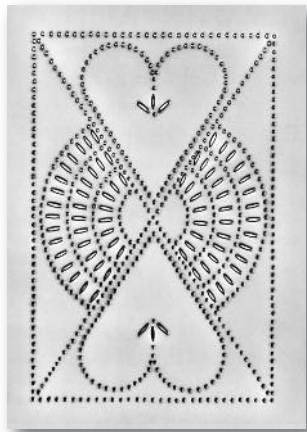

RP-1223 10 x 14



RP-1172 10 x 10

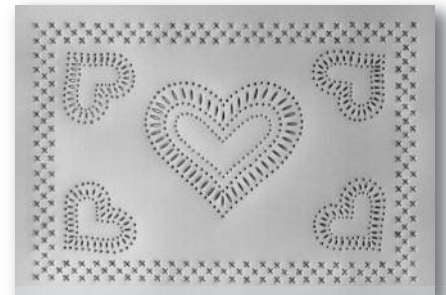

RP-1154 14 x 10

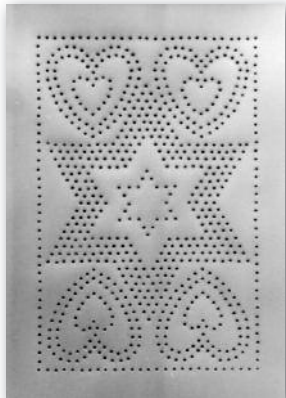

RP-1132 10 x 14

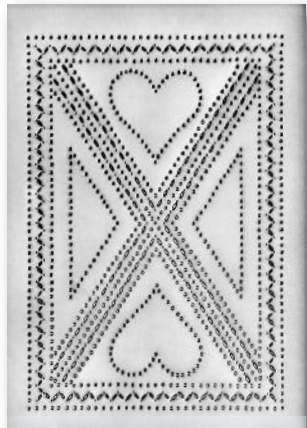

RP-1230-A 10 x 14



RP-1170A 12 x 10
shown: 14 x 10

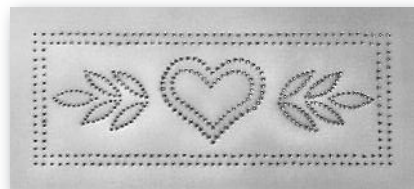

RP-1215 12 x 5

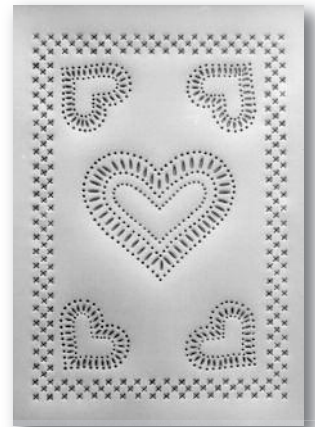

RP-1157 shown: 10 x 14
12 x 24

Pure and Simple

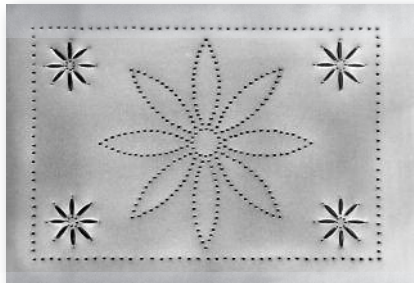

RP-1070 14 x 10

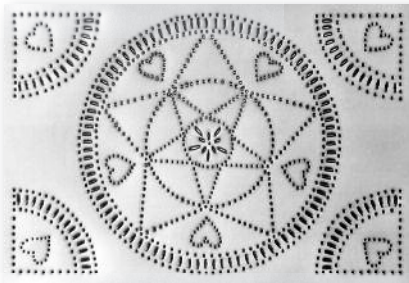

RP-1201 10 x 14
shown: 14 x 10



RP-1006 8 x 16
8 x 24
shown: 8 x 32



RP-1064 10 x 14

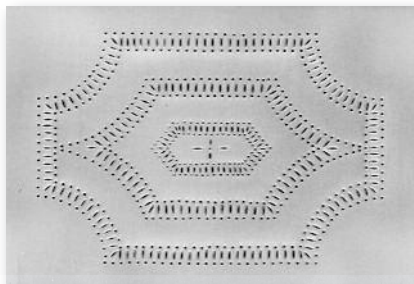

RP-1071 14 x 10

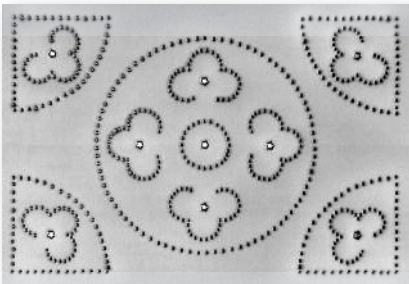

RP-1174 14 x 10

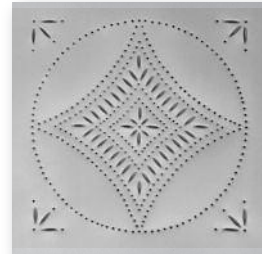

RP-1149 9 x 9

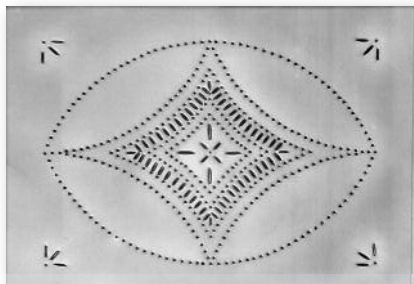

RP-1065 14 x 10

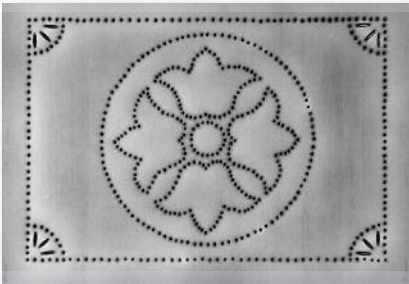

RP-1006A 14 x 10

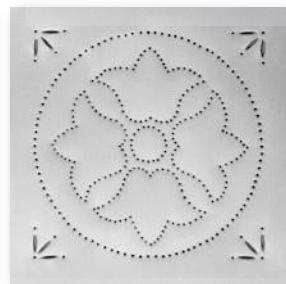

RP-1006B 10 x 10

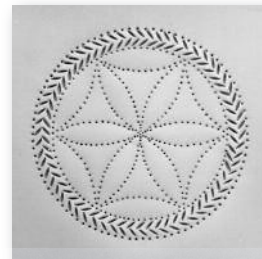

RP-1151 9 x 9

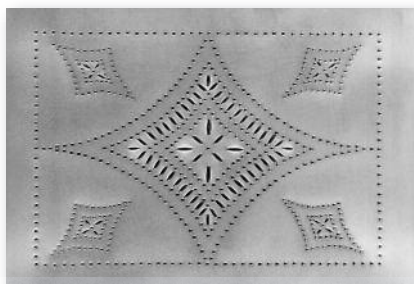

RP-1068 14 x 10

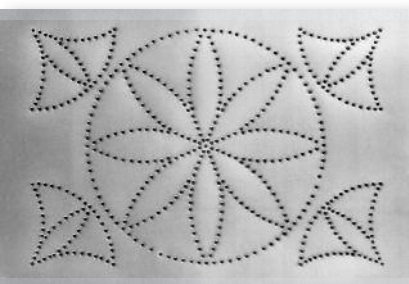

RP-1067 14 x 10

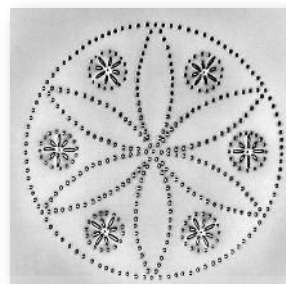

RP-1225 10 x 10

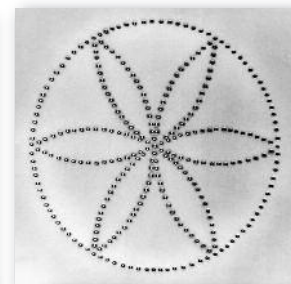

RP-1226 10 x 10

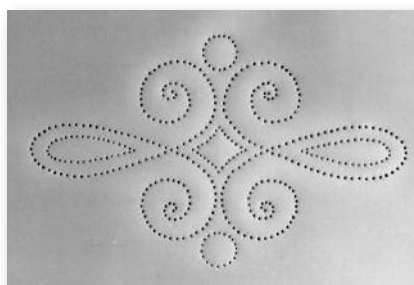

RP-1148 shown: 14 x 10
16 x 10

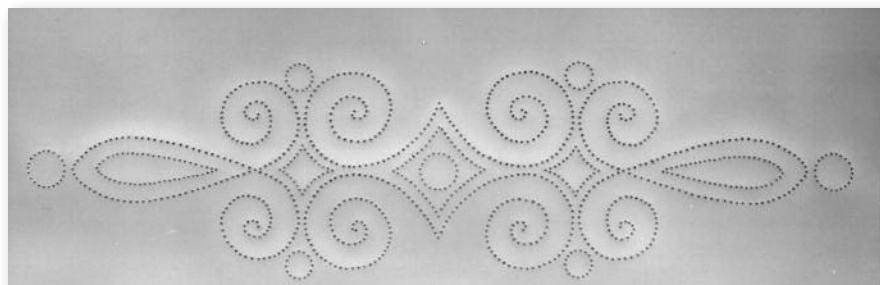

RP-1147 12 x 32

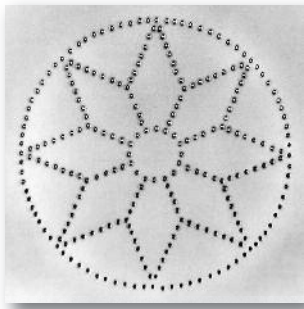

RP-1224 12 x 12
10 x 10

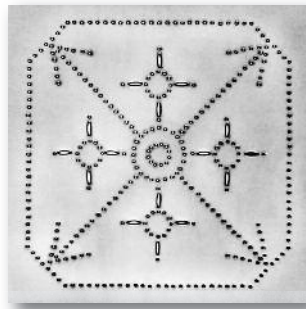

RP-1227 12 x 12
10 x 10

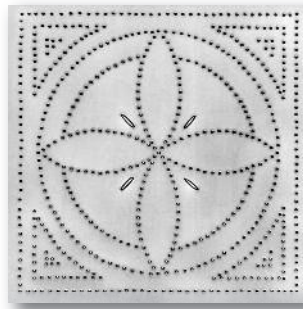

RP-1237 12 x 12

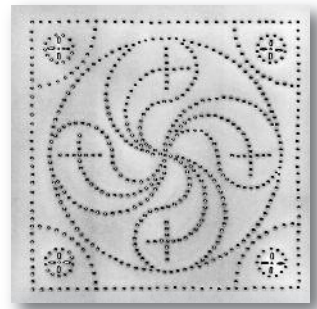

RP-1238 12 x 12

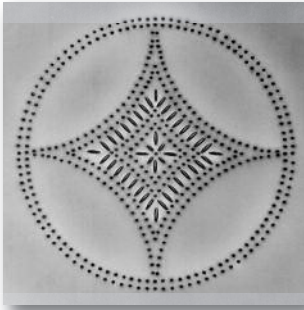

RP-1131 12 x 12

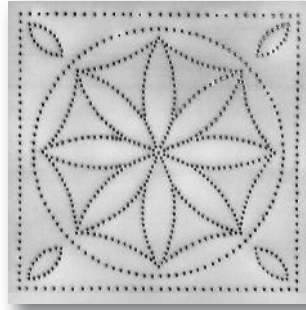

RP-1076 12 x 12

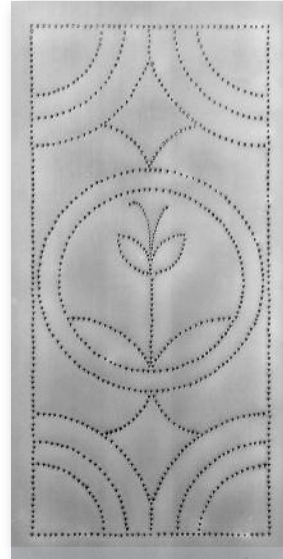

RP-1034 10 x 14
shown: 12 x 24

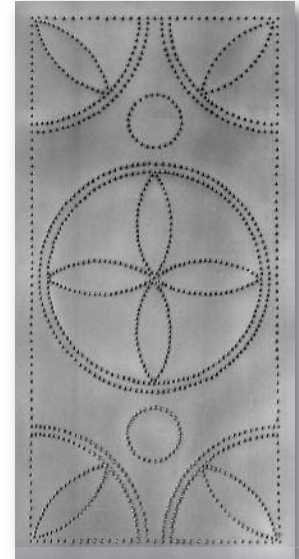

RP-1035 10 x 14
shown: 12 x 24

Many designs throughout the catalog can be used horizontally or vertically

Fantasy Facets

Inspired by the beauty of old-fashioned pressed and etched glassware, these designs are as at home with the Victorian as with the more contemporary, where a look and feel of pure tradition is desired.

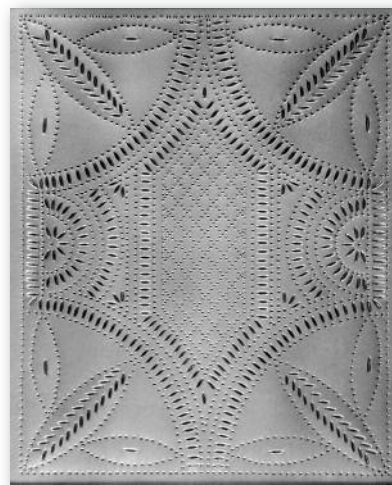

RP-1161A 14 x 18

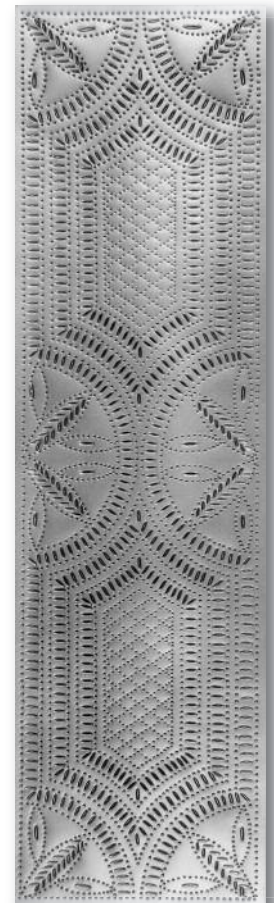

RP-1161 10 x 32

Many patterns can be adapted for most major manufacturers' refrigerators. See page 34 – 35 for more appliance adaptations!



RP-1033 Customized
(sold unframed)

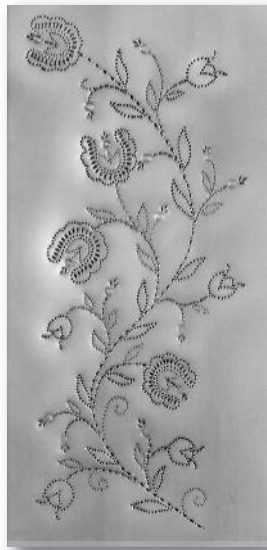

RP-1033/R 10 x 30
shown: 12 x 24

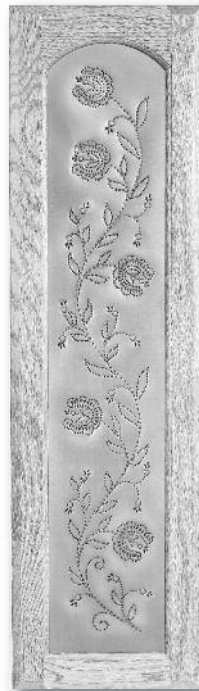

RP-1033 Customized
(sold unframed)



RP-1126 12 x 30

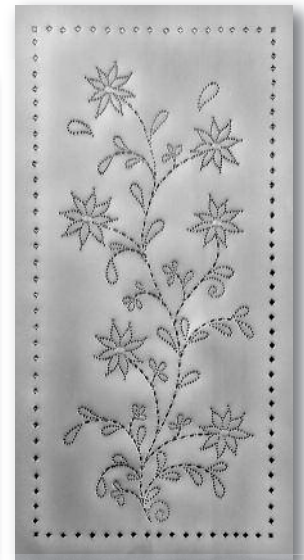

RP-1127 12 x 24

NOTE: When ordering any design on panels with arched tops, please include a tracing of the arch with your order for the proper placement of the design.

Botanicals



RP-1191 6 x 6

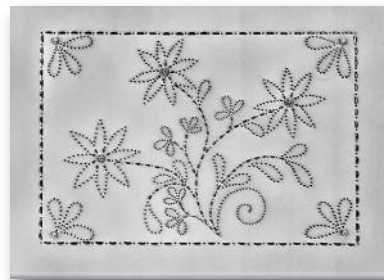

RP-1127 14 x 10



RP-1044 shown: 12 x 24
10 x 14

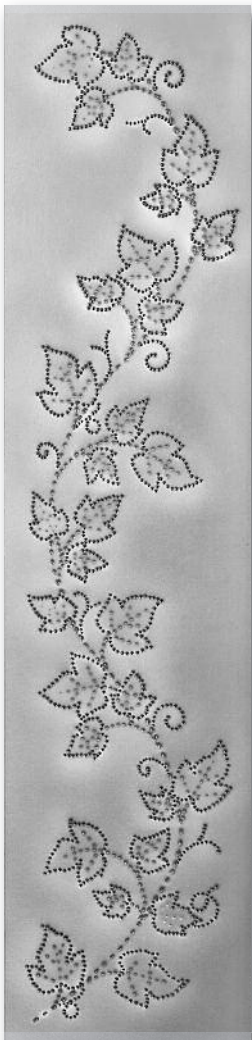

RP-1256 8 x 32



RP-1213 10 x 10



RP-1136/R 10 x 32
shown: 14 x 18

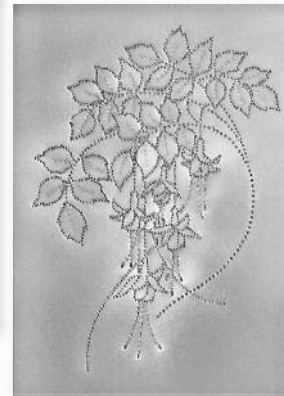

RP-1258 11 x 15

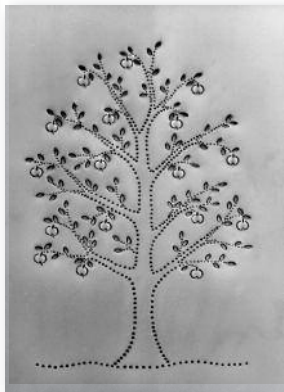

RP-1134/L shown: 10 x 14
12 x 24

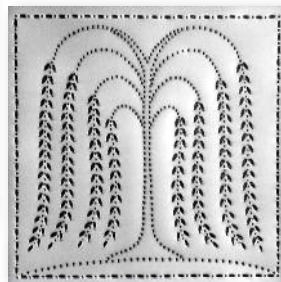

RP-1199 12 x 12

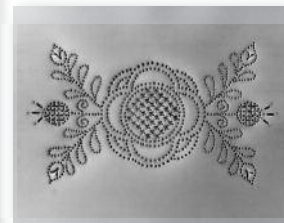

RP-1138 10 x 8

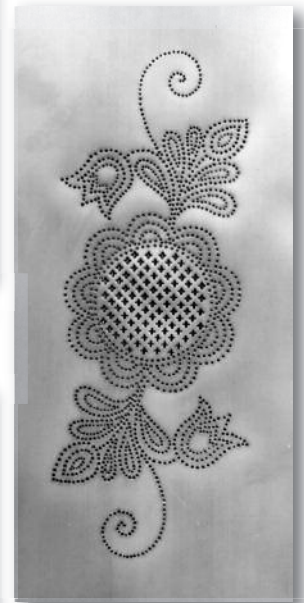

RP-1137 10 x 22



RP-1278

20 x 30 (sold unframed)

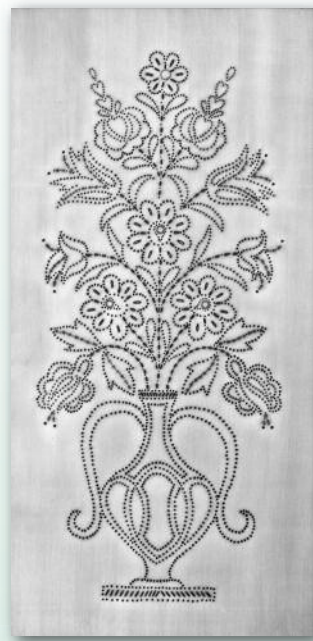

RP-1031

12 x 24

(sold unframed)



RP-1280

16 x 36 (sold unframed)

Our designs have been used for headboards, framed artwork, back splashes, room dividers – as many uses as your own creativity!



RP-1270
12 x 36



RP-1271
28 x 36



RP-1270
12 x 36



Large cherry armoire featuring RP-1249 "Fleur Jardin".



RP-1252

14 x 26 (sold unframed)



RP-1253

14 x 26 (sold unframed)



RP-1251

(sold unframed)

14 x 28



RP-1255

(sold unframed)

16 x 30



RP-1260

(sold unframed)

16 x 36



RP-1262

24 x 26 (sold unframed)



RP-1257

8 x 25
(sold unframed)



RP-1265

8 x 25
(sold unframed)



RP-1279

14 x 36
(sold unframed)



RP-1274

10 x 20

(sold unframed)



RP-1275

10 x 20

(sold unframed)



Tin plate finish panels add charm to this country kitchen with coordinating designs: RPA-2002, RP-1158 and RP-1159.



Featured with style RP-1137.



A fresh mix of floral designs in cabinets featuring style RP-1136!

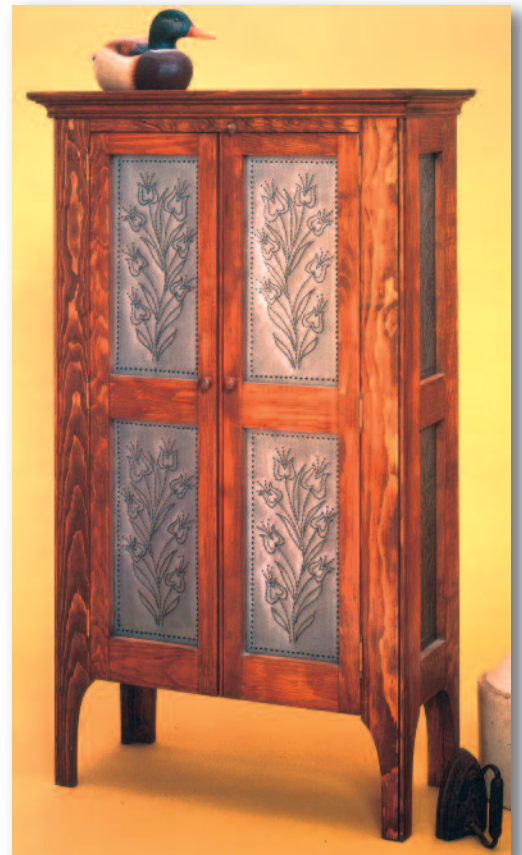

Features style RP-1047, as seen in "Woodworker's Journal," July/August 1989.



A finely crafted reproduction pine hutch features style RP-1168. Panel size shown: 13" x 20."



A delightful mix and match of Folk Art Favorites: style RP-1022 and RP-1023. Appeared in "Country Living - Country Classics," February 1993.



Perched on his branch of wild berries, our "Raven in Oval", RP-1166, appeared in "Better Homes and Gardens" magazine in August 1992. Panel size as shown: 10" x 14".

Choose your finish...

The very best in country tradition can be uniquely your own. Add the nostalgic allure of heirloom pierced tin, copper, or brass to your home.



Style RP-1167 warms a cozy corner. Featured panels are 14" x 18".



Stags leap and trees sway with the breeze in our RP-1024.



Mix and match designs...

Feel free to choose your favorites to mix and match in your cabinets. Shown at left, the top cabinet features style RP-1162 and the bottom cabinet features style RP-1163. (Appeared in "Country Woman magazine," May/June 1993.)

Reproduction Pine Hutch featuring style RP-1176.



Atmosphere...

From plain to appealing in moments! Change the character of your decorating scheme as easily as 1, 2, 3. Turn an unused piece of furniture into the focal point of a room simply by adding pierced metal panels. Kitchen cabinets utilizing panels on just one or two doors can quickly transform a room. High-quality, pierced metal panels from Pierced Tin Designs Ltd.® can easily fit into home design motifs ranging from traditional to primitive, from country to Southwest, and all the styles in between.



A breadbox features style RP-1108.



This cabinet used to store a cold winter's fare is brightened with RP-1046.

Featured with style RP-1169.





*Painted pine dry sink with cherry top features
RP-1245 "Tulips in Vase" (orig. Scott Co., VA 1850-80).*

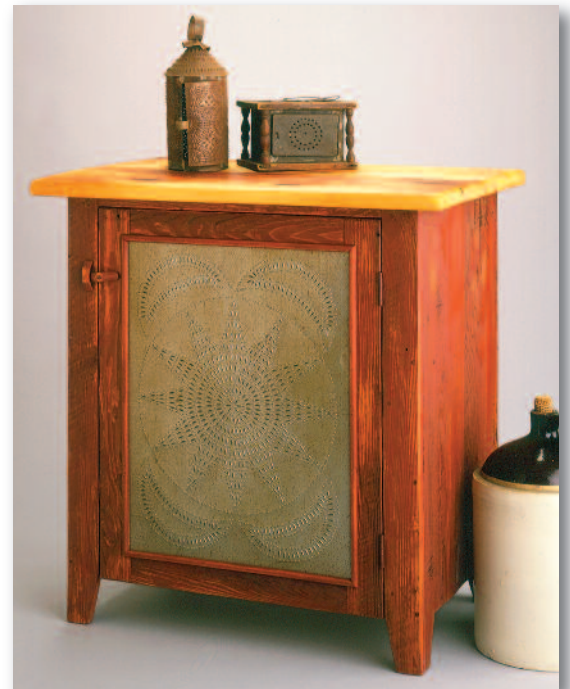

Featured with style RP-1128.



*Feel proud to call America your Home!
Style RP-1272 (28" x 19", sold unframed)
exemplifies your National Unity and Patriotism!*



*Panel style RP-1146 is
brilliant in beautiful warm
tones of a brass finish!*

*Painted pine hanging
cupboard with cherry trim
features style RP-1239
"Something Old"
(orig. Carter Co., TN 1840-80).*

*Available panel sizes are:
18" x 24" and 20" x 30".*





The Marigold, RP-1005, graces this simple but elegant buffet.



Featured with style RP-1005.



A flea market find is enhanced with panels in style RP-1107.



False grained and painted hanging cupboard highlights RP-1243 "Lace" (orig. Shenandoah Valley, no date).

Style RP-1135A appeared in "Woodworker's Journal", May/June 1993.

These traditional pie safe designs are shown with the piercing rough-side out, not only traditional for panels of this type, but the high relief allows the pattern design to stand out.

Historical Treasures

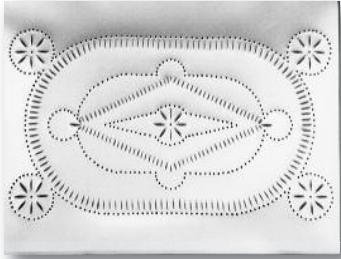

RP-1101 14 x 10

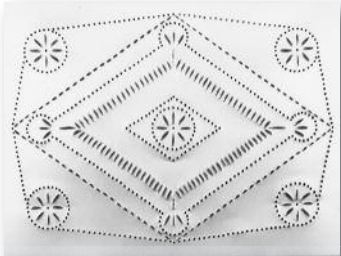

RP-1100 14 x 10

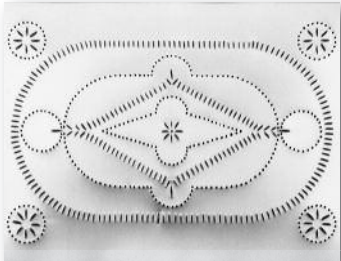

RP-1012 14 x 10

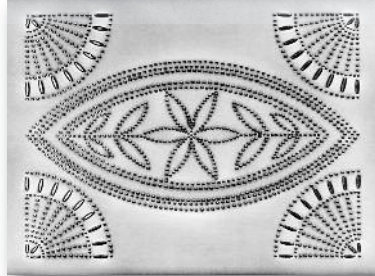

RP-1244 14 x 10
(origin unknown, circa late 1800's)



RP-1243 9 x 12
10 x 14
(originated Shenandoah Valley, VA
no date known)



RP-1245 shown: 12 x 20
10 x 14
(orig. Scott Co., VA 1850-1880)



RP-1246 16 x 24
(originated Lee County, VA 1850)

Mercer Museum Collection

(Courtesy of the Mercer Museum, Doylestown, PA,
Bucks County Historical Society)

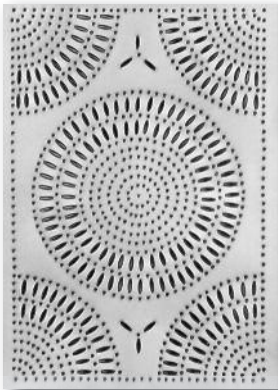

RP-1104 10 x 14

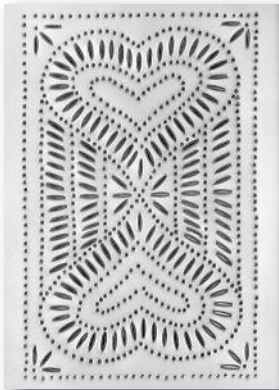

RP-1105 10 x 14



RP-1241 9 x 14
shown: 12 x 24
(orig. Grayson Co., VA 1830-1860)

Several years ago we were invited to closely study the extensive pierced metal collection at this unique museum which contains the life-long collections of Henry Chapman Mercer, renowned inventor and ceramicist. We were requested to adapt some of the most noteworthy designs to today's use both in do-it-yourself kits sold in the museum shop and for reproduction panels.



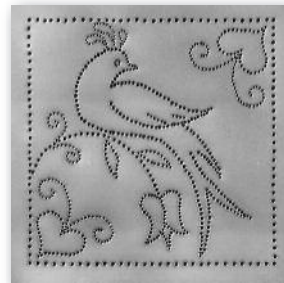

RP-1072/R 10 x 10

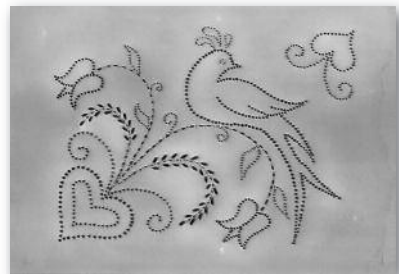

RP-1021/R *shown:* 14 x 10
18 x 14

Fanciful Folk Art



RP-1022/R 9 x 12
shown: 10 x 14
13 x 20
12 x 24



RP-1023 9 x 12
shown: 10 x 14
13 x 20
12 x 24

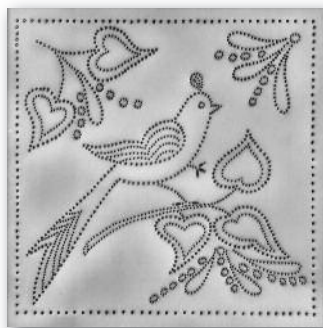

RP-1106/L 14 x 14



RP-1043/R 12 x 18
shown: 14 x 20

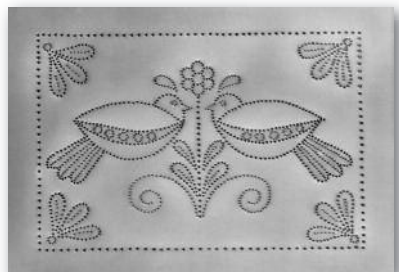

RP-1102 14 x 10



RP-1099 31 x 9



RP-1022/L 8 x 28



RP-1023 8 x 28



RP-1022/R 8 x 28

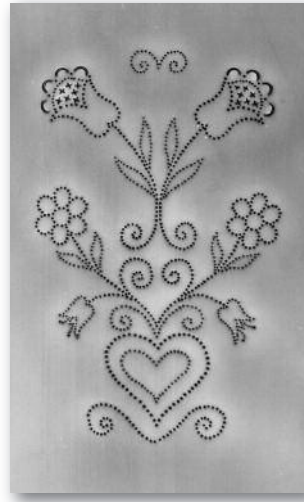

RP-1143 12 x 20

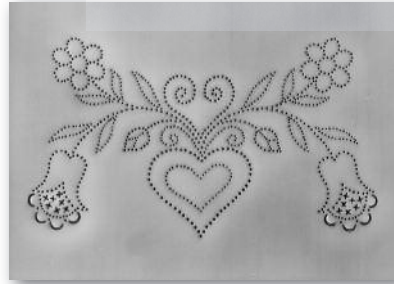

RP-1144 14 x 10
16 x 10



RP-1143 12 x 32

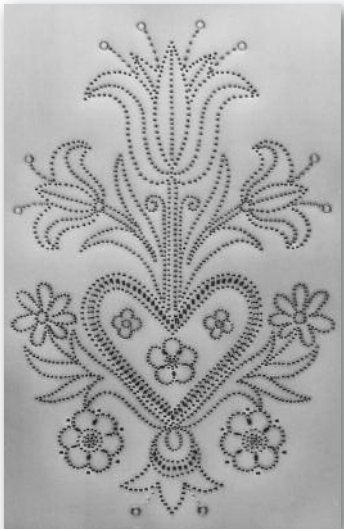

RP-1168 13 x 20



RP-1030 9 x 24
shown: 12 x 24

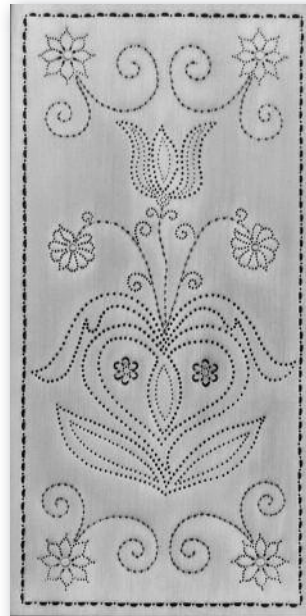

RP-1032 10 x 18
shown: 12 x 24



RP-1030 10 x 14

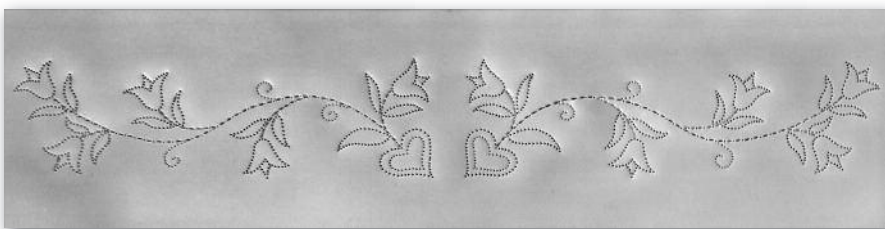

RP-1090 36 x 8



RP-1092 10 x 10



RP-1093/L 14 x 10

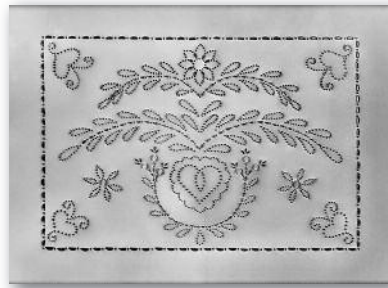

RP-1124 14 x 10

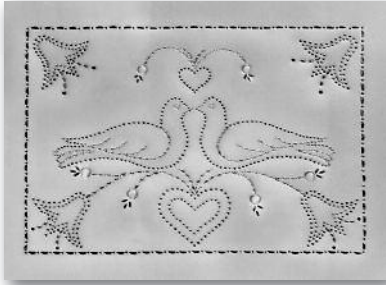

RP-1080 14 x 10



RP-1051 14 x 10

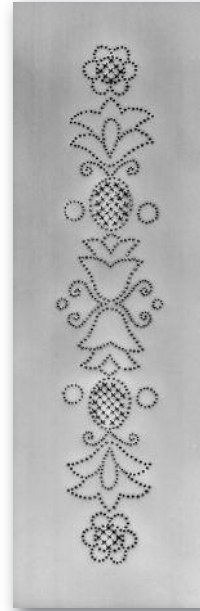

RP-1141 7 x 22



RP-1039 10 x 14
shown: 12 x 24

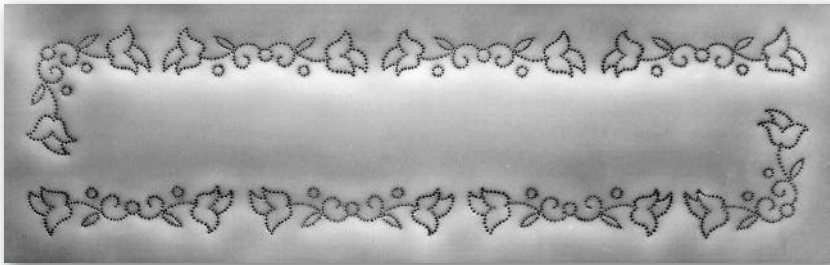

RP-1159 32 x 10



RP-1091 6 x 9
shown: 10 x 14

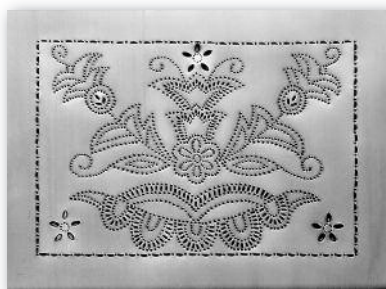

RP-1050 14 x 10



RP-1028/L 14 x 12

Select two patterns to mix-and-match in your own cabinetry for a style of your own!



CUSTOMIZED PANELS
MAKE YOUR PANELS
CUSTOMIZED
MIRROR THAT IMAGE

Dutch Plate Designs

Based on designs found on the charming salt glaze pottery from American and Western European folk art sources, these patterns in pierced metal are among our most popular.

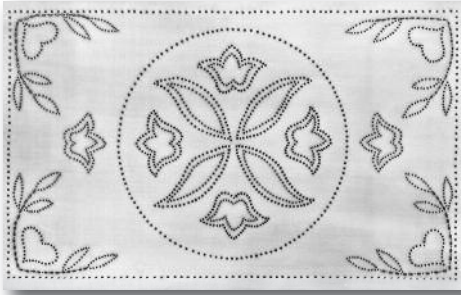

RP-1036

10 x 14
shown: 14 x 22

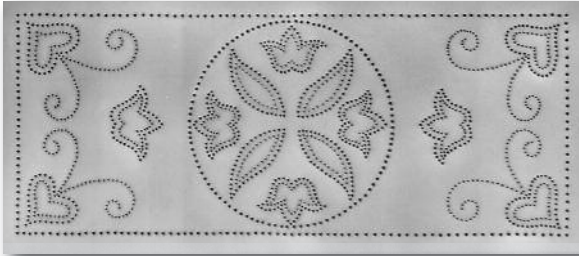

RP-1036A

20 x 9

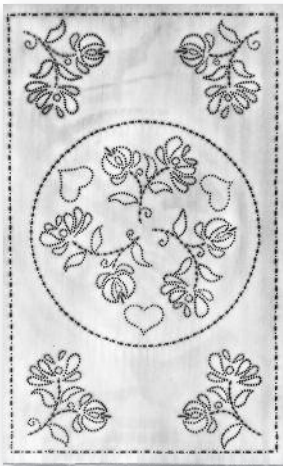

RP-1038

10 x 14
shown: 14 x 22

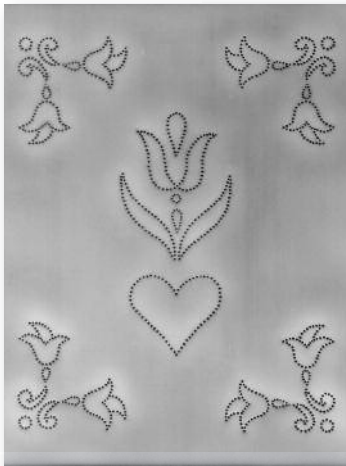

RP-1160

15 x 18

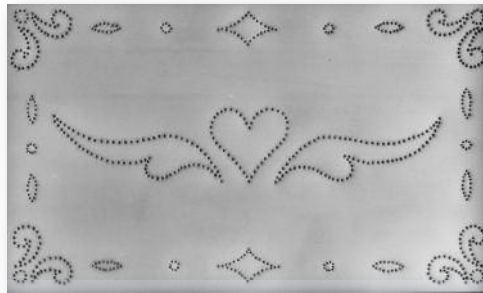

RP-1158

16 x 10

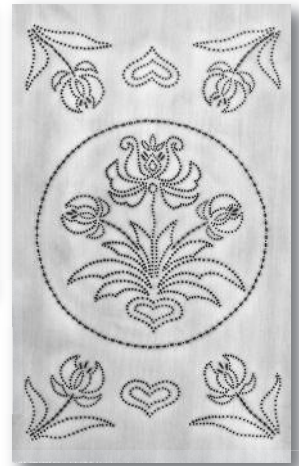

RP-1037

8 x 16
10 x 14
shown: 14 x 22

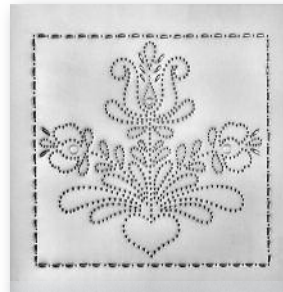

RP-1171

10 x 10

Many designs throughout the catalog can be used horizontally or vertically

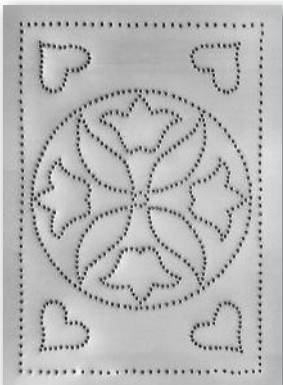

RP-1049

10 x 10
shown: 10 x 14
10 x 22
11 x 11

and Mini Folk Art Favorites

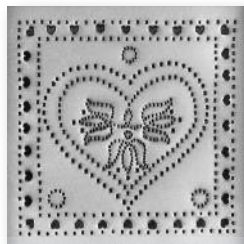

RP-1190

7 x 7

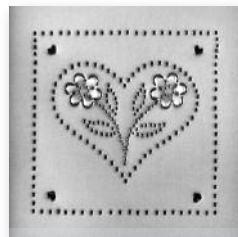

RP-1189

6 x 6



RP-1188

6 x 6

Buttermolds

These pierced metal designs were inspired by the fanciful patterns found on antique wooden and ceramic buttermolds taken both from our own collection and from many of those displayed at the Mercer Museum in Doylestown, PA. (Courtesy Bucks County Historical Society)

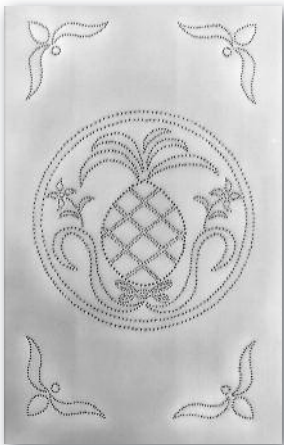

RP-1113 12 x 20
*10 x 10



RP-1112 12 x 20
*10 x 10

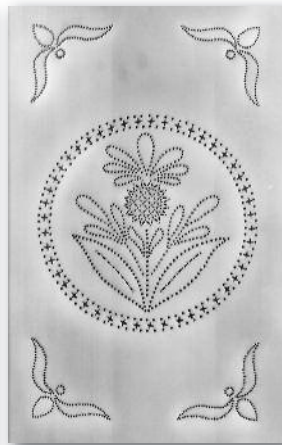

RP-1118 12 x 20
*10 x 10



RP-1116 12 x 20
*10 x 10



RP-1117 12 x 20
*10 x 10

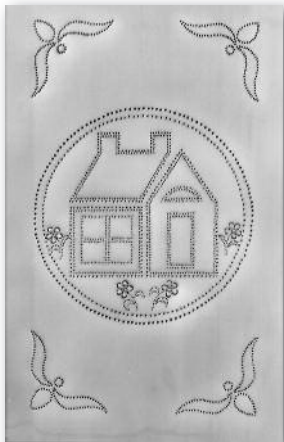

RP-1121 12 x 20
*10 x 10

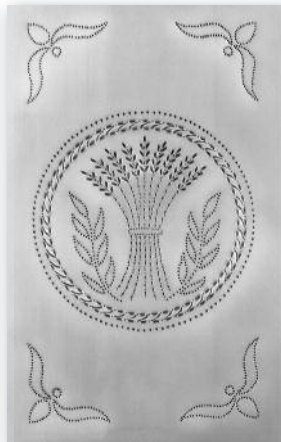

RP-1120 12 x 20
*10 x 10

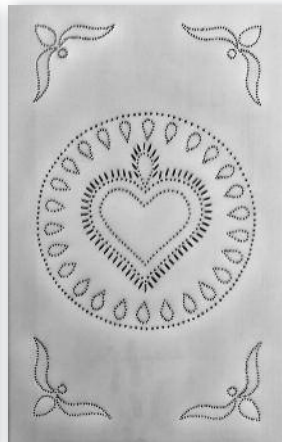

RP-1123 12 x 20
*10 x 10



RP-1111 12 x 20
*10 x 10

*Please note:
In our 10 x 10 size,
no corner motifs are used.

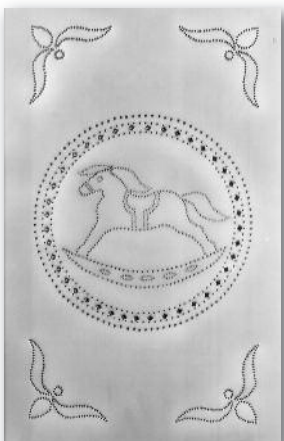

RP-1122 12 x 20
*10 x 10

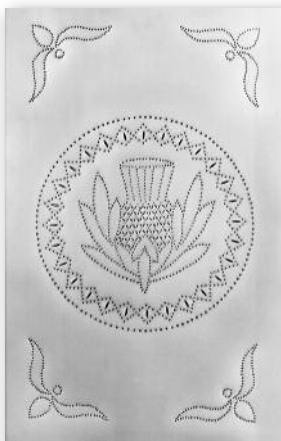

RP-1110 12 x 20
*10 x 10

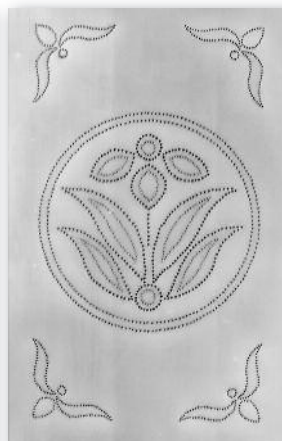

RP-1119 12 x 20
*10 x 10



RP-1114 12 x 20
*10 x 10



RP-1115 12 x 20
*10 x 10

Country Sampler



Cabinet features style RP-1162/L&R.

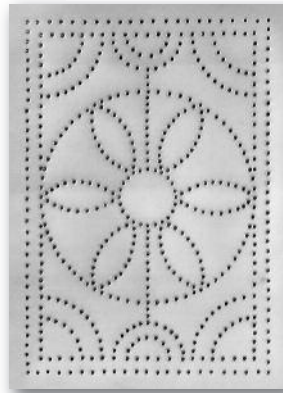

RP-1053 10 x 14

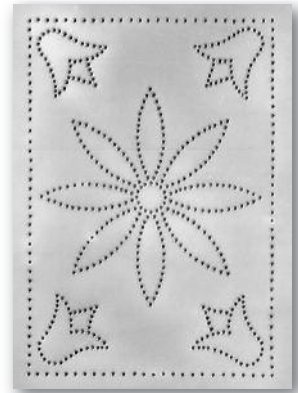

RP-1066 10 x 14



RP-1152 9 x 9

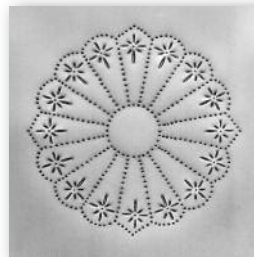

RP-1150 9 x 9
12 x 12

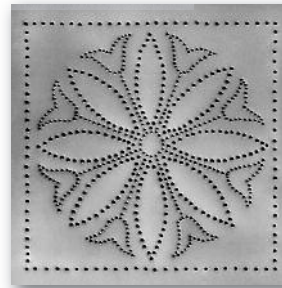

RP-1041 10 x 10



RP-1162 10 x 10
10 x 32



Featuring Style RP-1133

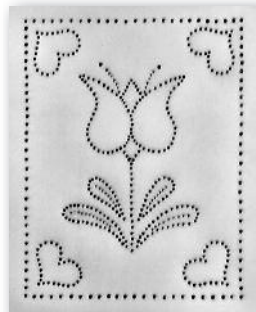

RP-1103 8 x 10



RP-1196 9 x 11

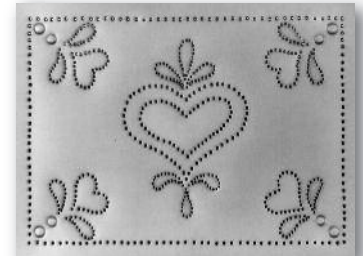

RP-1173 12 x 9

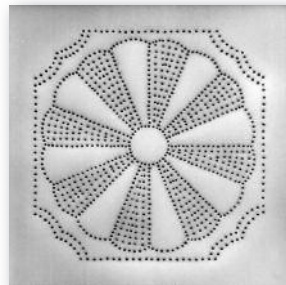

RP-1133 10 x 10



RP-1041 10 x 14
shown: 12 x 20

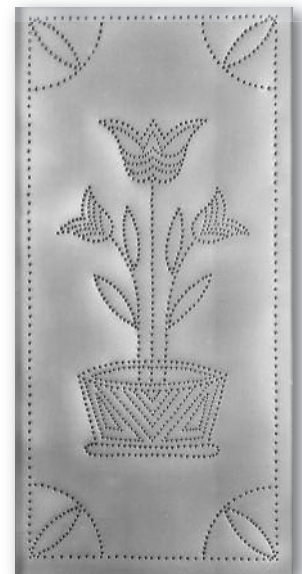

RP-1040 10 x 14
shown: 12 x 20
10 x 24

Animals & such...

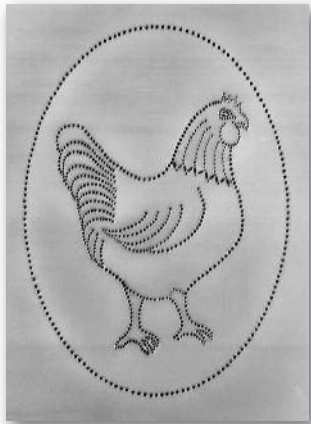

RP-1062 *shown: 12 x 16*
10 x 14, 12 x 24, 14 x 22

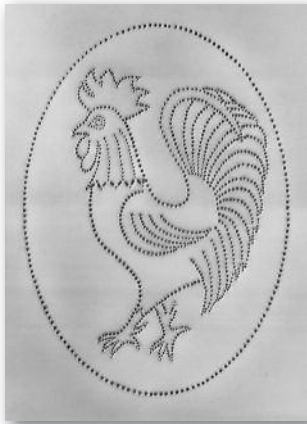

RP-1061 *shown: 12 x 16*
10 x 14, 12 x 24, 14 x 22

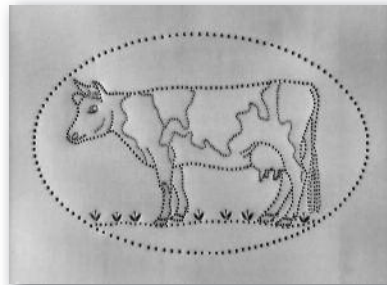

RP-1211 14 x 10

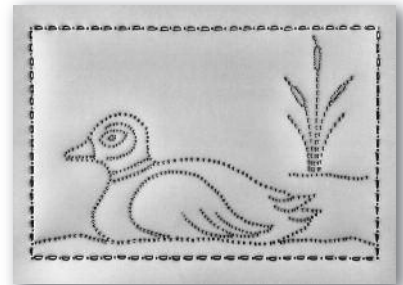

RP-1203 14 x 10



RP-1094/R 14 x 10

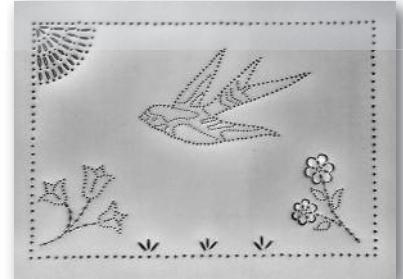

RP-1085/R 14 x 10

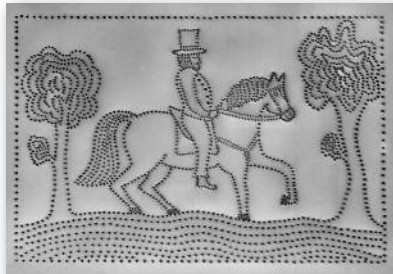

RP-1098 14 x 10

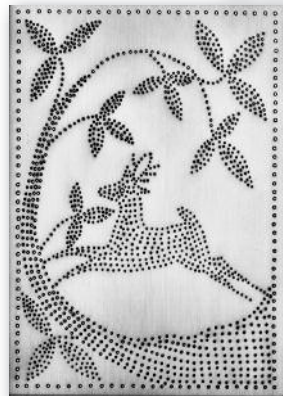

RP-1024 *shown: 10 x 14*
13 x 20
16 x 24

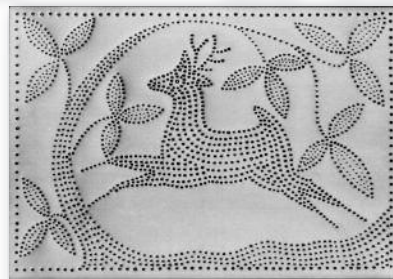

RP-1025 14 x 10

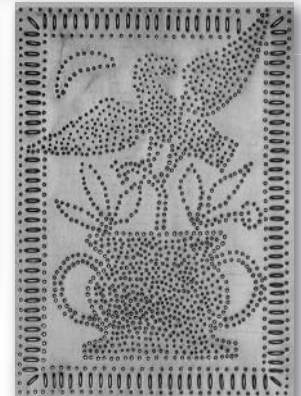

RP-1015 10 x 14



RP-1058/R 14 x 10

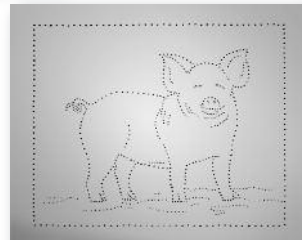

Custom

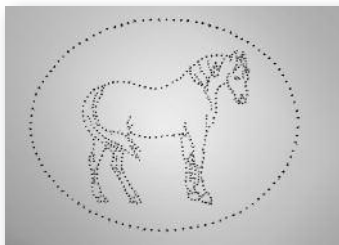

Custom

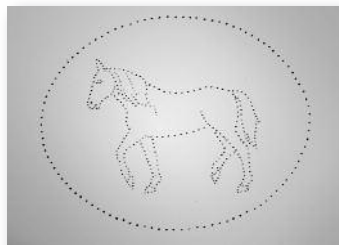

Custom

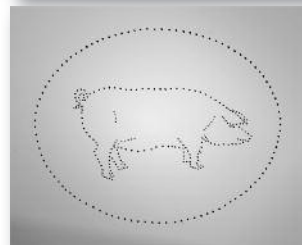

Custom

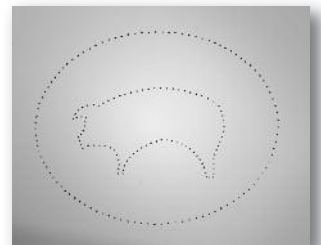

Custom

and Charming Carousels

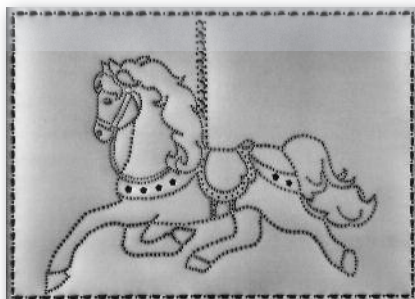

RP-1181 16 x 12

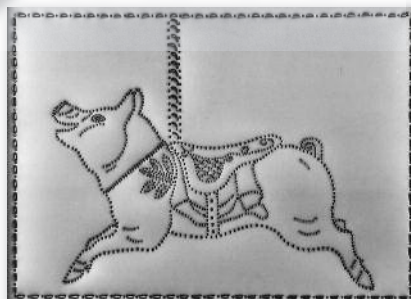

RP-1182 16 x 12

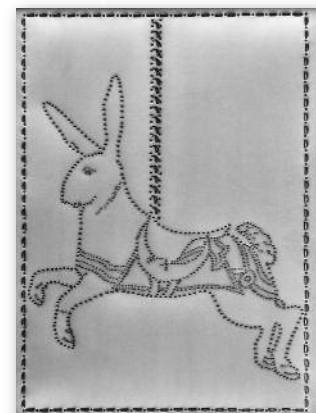

RP-1183 12 x 16

Simple Mottos

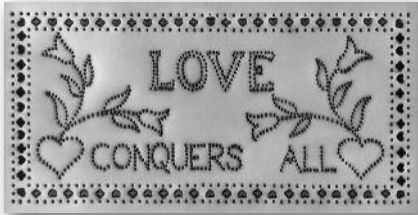

RP-1192 14 x 7½



RP-1206 14 x 11



RP-1208 14 x 12

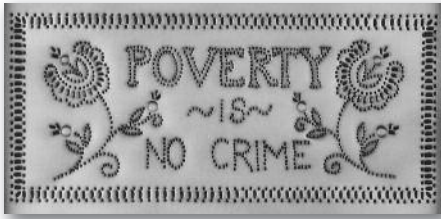

RP-1193 15 x 7½

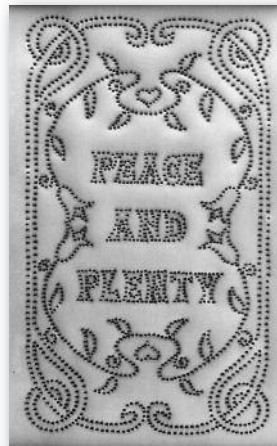

RP-1198 10 x 15



RP-1197 10 x 12

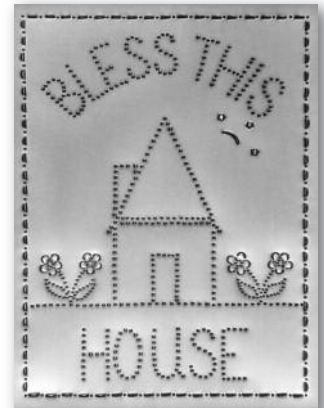

RP-1207 11 x 14



RP-1194 15 x 8

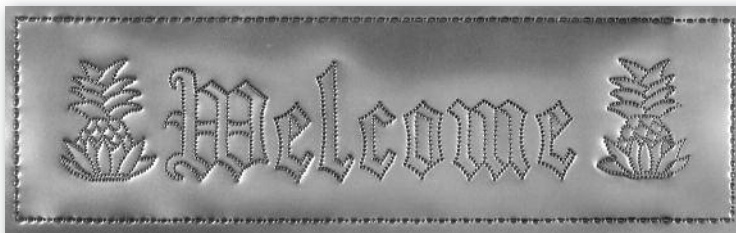

RP-1164 27 x 7



RP-1204 16 x 12



RP-1165 27 x 7

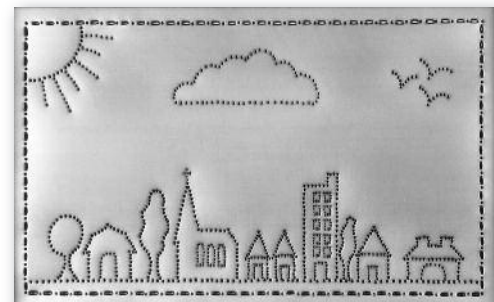

RP-1205 16 x 12



Dishwasher panels illustrate style RPA-1161.

Adapt our panels for your appliance front

A wide selection of designs featured in a fresh perspective — to brighten the fronts of dishwashers, refrigerators and other kitchen appliances. *(Not recommended for microwaves.)*

The letters “RPA” refer to adaptations of our Ready Punch line for appliance fronts. Please order appliance fronts by RPA number, noting size and finish desired.

See how these **award winning designs** can be adapted by us to fit your size requirements.

Panels are made to your size specifications within these limits. Other patterns and sizes are also available as custom pierced panels. Please contact our friendly custom service representative for a quote.

Due to the varying sizes encountered between appliance manufacturers, there will be variations in the design configurations based on size of tin and proportion of the design. All appliance panels will need to be quoted. Please supply us with the **OVERALL** sizes required for a quotation.

The background image features a customized award-winning refrigerator using RP 1073.

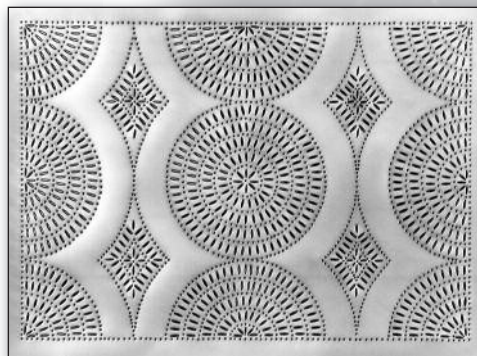

RPA-1073



RPA-1002

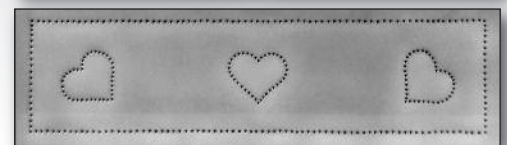
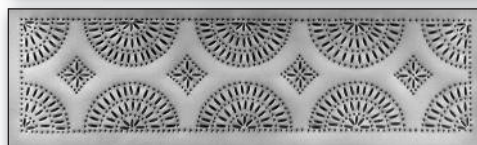

All appliance panels should be treated with a polyurethane prior to installation to prevent discolorations from exposure to food substances.

Personalized Appliance Front – RPA-1002

Choose the words or phrase that best suits you and we will create it on these metal panels, making them truly one-of-a-kind! Some ideas: Bless This House, Welcome Friends, Your name(s), Katie’s (your name) Kitchen, I Hate To Do Dishes!, etc. Make sure phrase contains no more than 17 characters (spaces don’t count.) Bottom panel contains as many hearts as you wish. How about one for each member of the family?

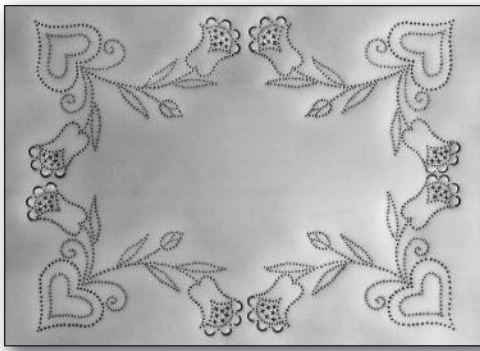

RPA-1100

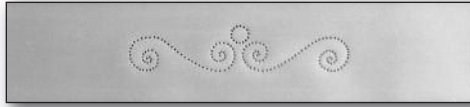
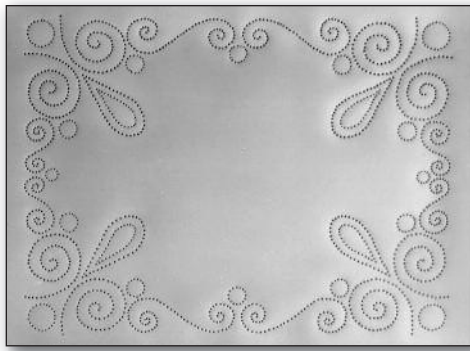

RPA-2001

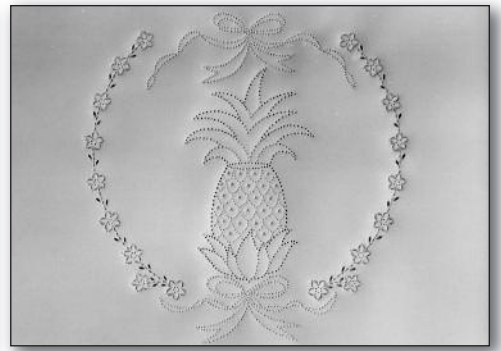

RPA-1029

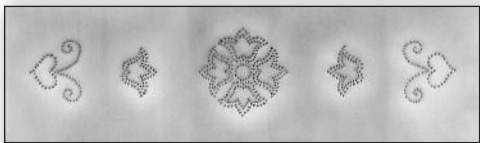
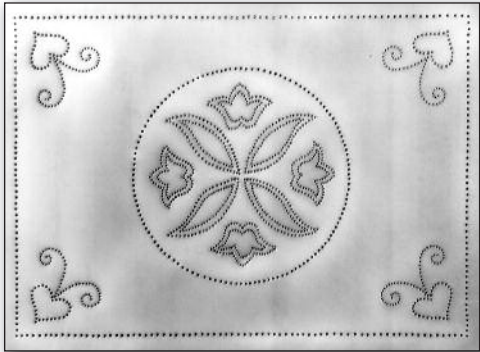

RPA-1036

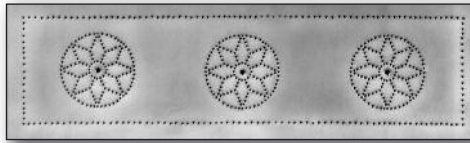
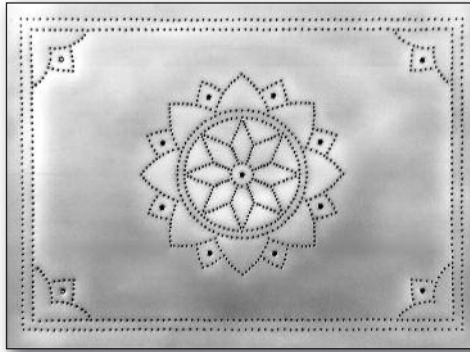

RPA-1005

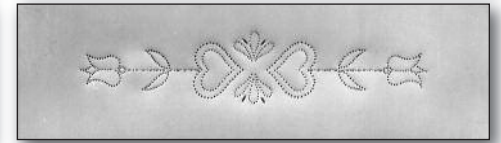
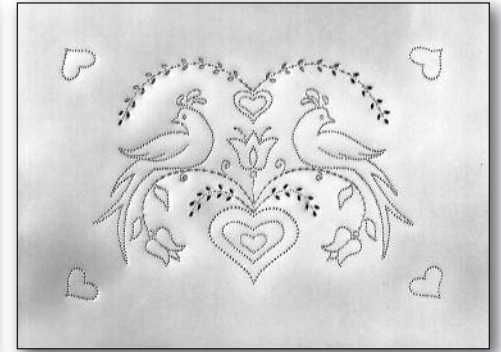

RPA-1072

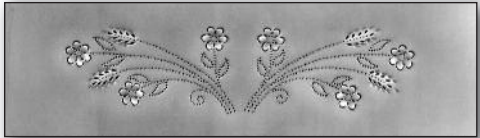
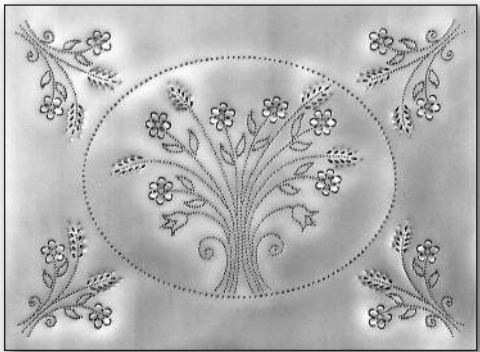

RPA-1042

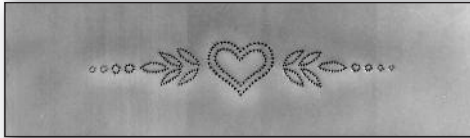
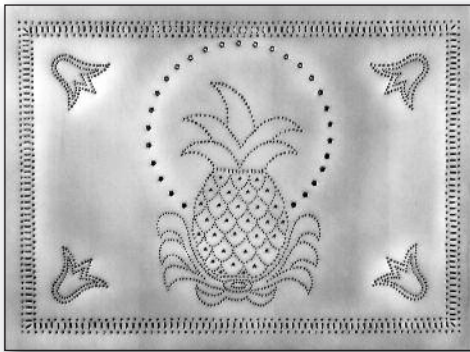

RPA-1063

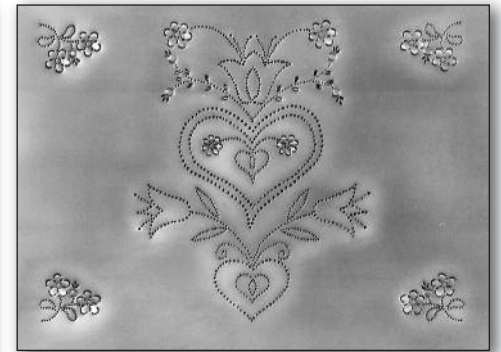

RPA-1030

Why not have matching panels made for your kitchen cabinets to give your whole kitchen a stylish new look! See our extensive collection of Ready Punch™ panel designs to choose your favorite.

Appliance front patterns are not limited to those illustrated. They can usually be adapted from other patterns to echo your choice of cabinet panels. Please contact our friendly customer service representative for a quotation on appliance front designs not shown here.

Customize your panels with Border Designs!

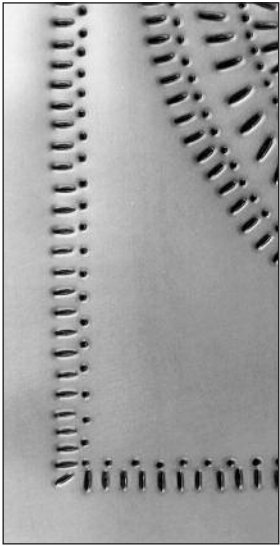

B-001 One & One

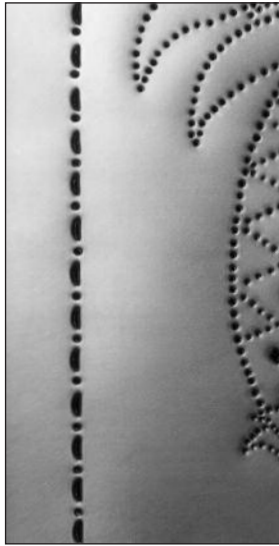

B-002 Beveled Chisel

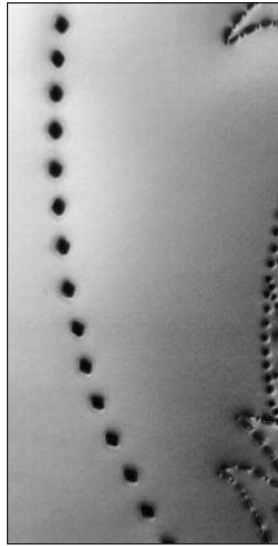

B-003 Diamond

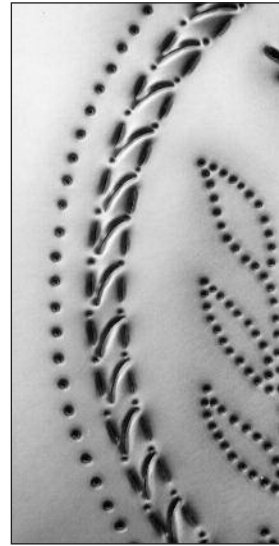

B-004 Rope

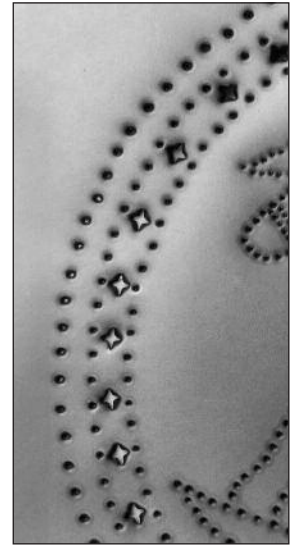

B-005 Quatrefoil in Channel

This collection of special borders enable you to further individualize your choice of panels. *It's easy to order!*

Just select your panel design from the **Ready Punch™** collection and choose a border from any of those pictured. Give us your dimensions and choice of metal finish and for a small extra charge we will personalize your panels with the border design of your choice. Please be specific by using the name and number of the border and basic pattern desired. Prices for special borders must be figured by us, so just contact our friendly customer service representative for a price.

Although closeups of these borders show many in oval or rectangular applications, they can just as easily be accomplished in squares or circles.

Please note border by the "B" number code, i.e. B-006. Don't forget to give us the RP number of the basic panel designs as well!

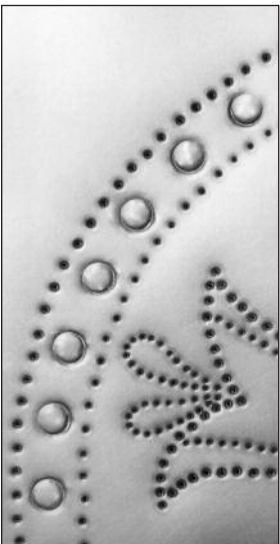

B-006 Rings in Channel

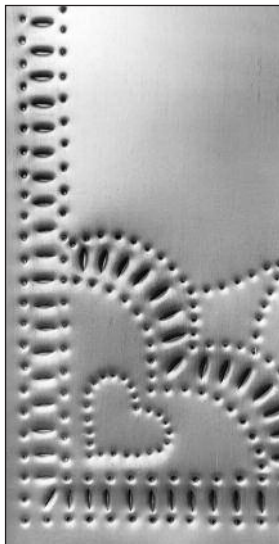

B-007 Chisel in Channel

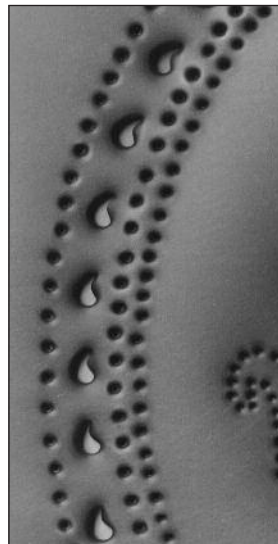

B-008 Curved Leaf
in Channel

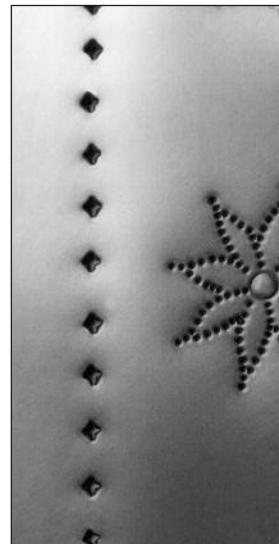

B-009 Quatrefoil

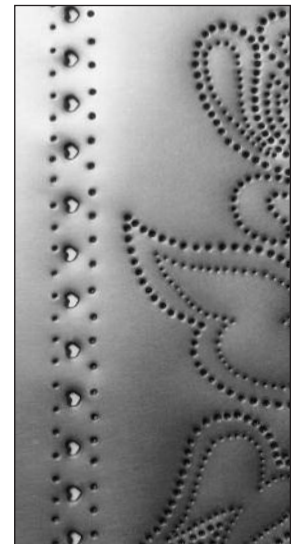

B-010 Hearts in Channel

Front Mounting Self-Edged Panels for a short cut to style!

Use self-edged pierced metal panels to make installation a snap!

Redecorate your cabinetry, as we did here with a few splashes of paint and easy-to-apply pierced metal panels. These panels were installed using our exclusive self-edging technique of folding or applying special edges to the unfinished panel and then simply tacking through the holes in the border design onto the existing door. This technique of surface mounting is great for both new cabinets or older ones, as well! The pictured cabinets had plain flush doors, but this type of panel can be used on many different types of doors making the use of molding to secure the panels unnecessary.



Samples of the edging technique are pictured below. IT'S SIMPLE TO ORDER! Just decide which of the edges would fit your needs (check page 39 on installation techniques to determine which type door is most like your own).

Then when ordering your finished panels, tell us which of the edges you wish to have and we will figure the extra charges for you. Special edges are available on finished panels only. Pricing for self-edged panels is determined by the size of the finished metal and is nominal compared to the cost of using molding.

Cabinets featuring RP-1031 with Folded Edge.

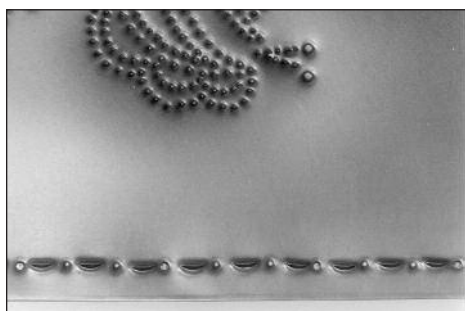

Folded Edge

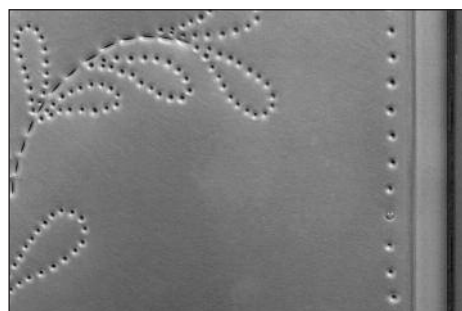

Raised Panel Edge

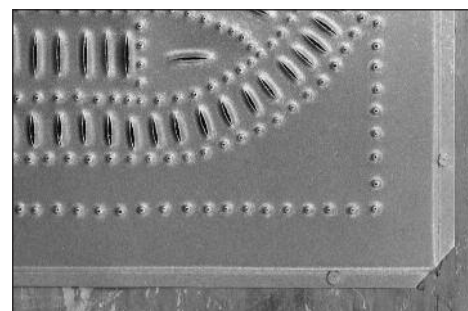

Beveled Edge

Please note: Folded edge panels are $\pm 1/16$ " in any given size due to the fact that the metal "stretches" when this edging is applied. Therefore folded edges are not recommended for "fitting in" to a space. Folded edge panels should be reserved for surface mounting only.

Self-edged pierced panels, drawer fronts and custom border designs to personalize your home.

Now, anyone having a few minutes, a hammer and some tacks can spruce up their cabinets at a cost far less than buying new or re-surfacing old ones. The simple ease of applying these panels adds to their appeal.

Our exclusive drawer front panels in two shapes.

A new and different way to refurbish a piece of furniture. Choose from **oval or rectangle panels**. Drawer front panel patterns are chosen by us to relate to the panels we make for your cabinet doors. These small self-edged panels are tacked onto the outside of the drawers just as simply as the self-edged panels are installed. With the drawer fronts you have a choice of **folded or beveled edges**.

As a rule of thumb: Overall size of the metal on the drawer fronts should be a minimum of $3/4$ " smaller than the drawer itself, thereby simplifying measuring for these small panels. Due to the custom nature of these applications, there are no standard prices for these edging techniques and drawer fronts. Please call our friendly customer service representative for a quote.

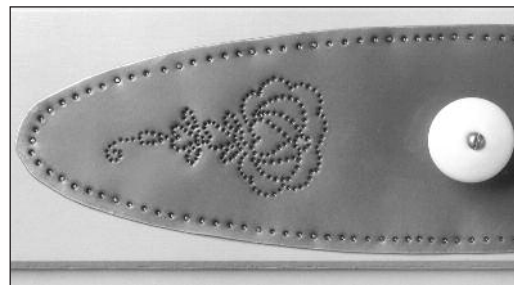

Self-edged small panels are pierced to match your cabinet panels (please let us choose a coordinating design). Can be easily tacked onto drawer fronts. Drawer handles are attached on top of the metal panels. Porcelain knobs are shown here, but regular handles can be used as well.

Ordering Information

(Custom and Standard Sizes)

Illustrations:

- A - Overall Width
- B - Overall Height
- C - Exposed Width
- D - Exposed Height

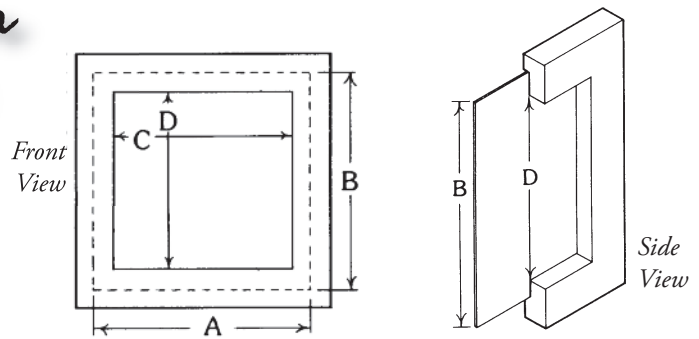

To order STANDARD size panels, include the following information when placing your order:

- Ready Punch™ catalog number (i.e., RP-2020)
- Name of finish
- Quantity and sizes of panel(s) desired
- Select price from appropriate column
- Left or right facing, if applicable
- Maintain a copy of order for your records

☞ Panels can be made either right or left facing. Please specify when ordering.

☞ We normally allow $\frac{3}{8}$ " on all panels shown with borders, which means the border starts approximately $\frac{3}{4}$ " from the outside edge of the panel. If your exposed area differs greatly from this, please include EXACT measurements of each area.

☞ Overall size of the panel ordered (i.e. 9 x 12) is the exact size of the panel you will receive.

☞ Each order for custom-made panels is given our personal attention and is made to your exact specifications concerning size, design and finish. **Please allow four to six weeks for shipment of your completed panels.** Our policy is: "Never sacrifice quality for expediency."

☞ Due to the handmade nature of our work,

some items may vary slightly from the illustrations. Proportions and slight variations may occur with different size panels.

☞ All panels are treated with a special protective coating which, when care instructions are followed, should maintain their original appearance indefinitely.

☞ Please order carefully with regard to type of metal desired. Once sealed, their appearance cannot be altered. Check the color photos on the inside back cover, or order our metal samples for accurate ordering. There are no returns on pierced panels (damage in transit excepted)

☞ Appliance Front Panels:

To order RPA Appliance Front Panels, please provide the following information:

- Pattern (RPA) number
- Name of finish

• Size (width and height) of each of the inserts desired.

☞ Refrigerator/Freezer Front Panels:

To order RPF Refrigerator/Freezer Front Panels, please provide a sketch of the panel arrangement, supplying panel sizes, pattern number and finish. These inserts are always considered custom and must be quoted as to price. Many of the designs shown in our catalog can be adapted to these large size inserts, in addition to the ones pictured.

☞ Panels with exposed area other than square or rectangle (Arched tops, ovals, etc.):

When ordering any design to fit into a specially shaped area, please include a tracing of the actual opening with your order to insure proper placement of the design.

Panels are made in rectangles or squares only. We cannot cut special shapes.

For your protection, orders for CUSTOM PANELS must be placed IN WRITING through fax, email or standard mail. See instructions on how to order standard sizes.

Frequently asked questions:

Should I have my panel rough or smooth side out? Old pie safes and Revere lanterns had the rough side out for practical reasons. The rough edges would prevent flying insects from entering the food safes and kept out dust as well. In the case of lanterns, the rough edges kept strands of hay and dust from entering the candle lantern and igniting when the farmers took the lantern out to the barn. While the more traditional and primitive patterns look lovely with the rough side out, there is no hard and fast rule concerning this — today it is just a matter of taste.

Won't the rough edges cut if you run your hands over them? We use special lampmaker's tools that do not leave as rough an edge as would be left if an awl or screwdriver was used to pierce the metal.

Why are some finishes only available as finished panels? Over the years we have experimented with many different compounds which

give an aged patina to the different types of metal we sell. Many of the unusual finishes we have developed are applied *after* the piercing is completed, therefore some are unavailable blank.

You stamp these designs out with a machine, don't you? Although toward the end of the last century there were a number of companies producing pierced metal panels in this fashion, we have committed ourselves from the outset to the phrase HANDMADE IN AMERICA. Every panel we complete is the product of many hours of hand drawing, piercing and finishing. We never have and never will use machines to pierce these panels.

Can we come to visit your shop? Since our inception late in the '70s, we have at times had a small gallery where folks could visit. But after moving here to the mountains of north central Pennsylvania in 1987, we decided to maintain our business as strictly a mail-order firm..

Our work has been greatly honored to have appeared in these fine publications:

Time Warner's "Shaker Furniture"

Wood Magazine

Country Living Magazine

Woman's Day

Country Decorating Ideas

Country Handcrafts

Early American Life

Country Wood Projects

Woodworker's Journal

as well as mention in:

Better Homes and Gardens

Good Housekeeping

Crafts

ABC Home Show

Norm Abraham's New Yankee Workshop.

We are proud that our products meet the high standards requisite for inclusion in these wonderful sources and we sincerely appreciate the affirmation of our work.

Mounting Instructions

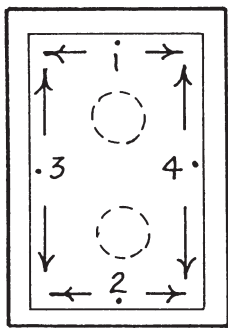

Place door on firm padded surface to prevent scratches. Place metal panel onto the door. Position, using weights to flatten the bow and start tacking by piercing holes (if not prepunched). Start in the center and follow through on all four sides, alternately placing tacks on top, bottom and sides 1½" - 2" apart.

For installation of Ready Punch™ Appliance Panels:
Follow manufacturers' instruction.

Flush Door

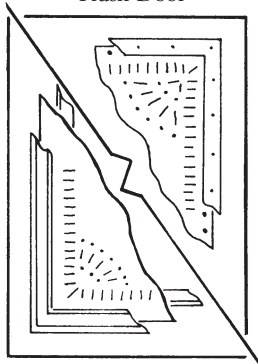

Raised Panel Door

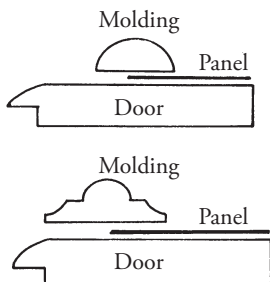

Front-Mounted Panels

Flush door application is the same as for raised panel doors. Cover the desired area and finish off with molding. In the case of metal doors, panels are held in place using sheet metal screws instead of tack or brads. A few of the types of moldings that can be used to hold panels in place would be shoe, stop, screen, cap, cove, half-round, mullion, etc. Surface mounting the tin and finishing off with molding coordinated to doors not only holds the tin in place but adds a decorative appearance. When applying panels to old, worn-out doors on kitchen cabinets, be sure new finish (paint or stain) has been applied before installing new panels.

Rabbeted Door

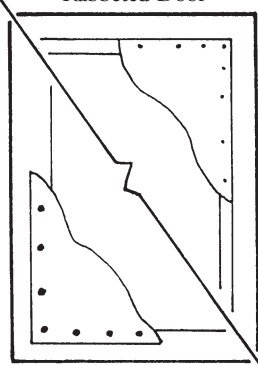

Unrabbeted Door

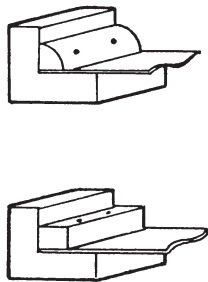

Rear-Mounted Panels

Panels are attached to the inside frame of rabbeted doors as follows: use strips of wood molding behind the panels and tack into place all around to secure. On very small openings, glazier's points may be used in lieu of molding. On unrabbeted doors, panels can be attached to the back of the frame using tacks to secure.

Tacks and brads for attaching panels	#18 Brad x ½"
are available in packs of approx. 100	#18 Tack x ½"
Each pack	\$ 1.00

Self-Edged Panels

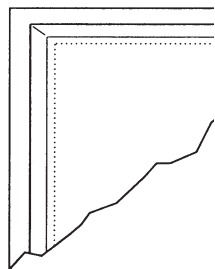
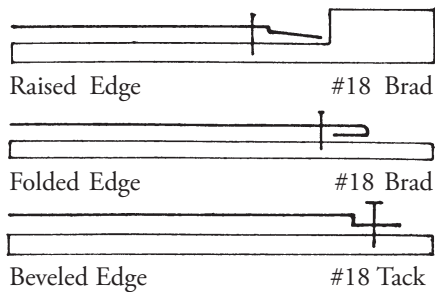

Self-edged panels are easily mounted with the use of #18 brads.

There are no hard-and-fast rules about how much of the door should be covered with the metal panel. It is a matter of taste and/or necessity. Door and drawer handles can be placed either on the metal panels or kept on the exposed part of the door.

Care of Your Finished Panels

To clean panels merely wipe with a soft, dry cloth. Should it become necessary to use a liquid cleaner, use only a mild, non-abrasive detergent diluted in water and wipe dry immediately. Never use waxes, polishes or abrasive cleansers on panels as they may damage the protective coating. With proper care, your panels should keep their original appearance indefinitely.

These metals are industrial materials that are used for craft and decorative purposes. Occasional minor defects are a result of mill handling and are unavoidable. While every attempt is made to present the "best side forward," there may be some visible faults. Many find this adds interest and character to the work.

We thank you for your order and we are gratified by the confidence it reflects in our work. We have a firm commitment to quality and we will complete your order with care, keeping your satisfaction in mind.

While no guarantee is expressed or implied concerning durability of protective finishes on these panels, by taking care that the panels do not come in contact with substances which may mar the finish such as furniture waxes and polishes, abrasives, corrosives, etc., your panels should retain their original appearance indefinitely.

Custom Sizes, Custom Designs? Absolutely!

Custom Sizes - No Problem! Don't be concerned if the panels you need don't fit into the "standard" sizes noted in the pricing schedule. Here's what to do — telephone, write or fax us indicating the quantity of panels of each size you need, the particular metal finish and RP pattern number.

Custom Designs - No Problem! If none of our patterns suit your needs, either make us a sketch of what you'd like to have or send examples, such as pieces of wallpaper, pictures of floor tiles or a sketch you've made. We'll determine feasibility and get back to you shortly with a price.

If you have a whole kitchen project, it might be a good idea to give us a layout sketch (this can be just a rough idea of cabinet layout, no artistic ability necessary) to help us make the proper panels for your individual needs.

If you write, please send a stamped, self-addressed legal size envelope to speed our reply on it's way back to you.

When ordering panels with arched tops, please enclose an exact tracing of the arch — they're all different!



Every panel is carefully and individually created in our studio, pierced by hand by our skilled crafts-people.

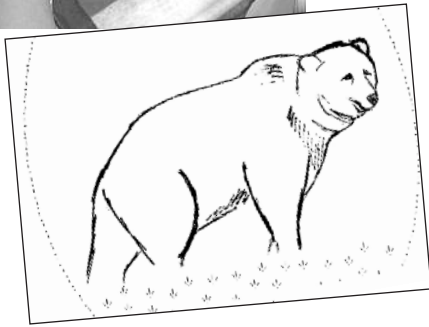

Custom designs begin with a concept sketch of your requested subject.



Your custom panels are created to your exact specifications for size and finish!



A



B



Order sample swatches of our finishes...

While the samples pictured here are excellent representations of the actual metal, photography has its limits. Therefore, we suggest you order our sample pack of "mini panels," one of each of our exclusive finishes with a small pierced design, similar to the larger completed panel. This allows the opportunity to "live with them" for a while to make certain you have chosen the metal that's **just right** for your environment. Not only can you see how the color will work for you, but you can sample the quality of our workmanship as well. Swatches are indispensable when matching colors on old panels or choosing the proper finish for that new project!

To help you choose the correct metal for your project, we have assembled a sample set of metal swatches. Each measures approx. 3½" x 5", and is pierced with an attractive design. The samples are available as follows:

Sampler pack (12 swatches) \$ 25.95 PPD

Sampler pack (12 swatches), *with catalog* \$ 29.95 PPD

Single swatches are available for \$ 3.50 each ppd.

OR please send \$2.00 per sample and a self-addressed, DOUBLE-STAMPED, legal size envelope for EACH sample ordered.

Brass (30 gauge) Solid BrassMax. width 24"
An impressive material for a lavish attention-getting appearance.

Antiqued Brass (30 gauge) Solid BrassMax. width 24"
Burnished and elegant – for a feeling of tradition and formality.

Copper (30 gauge) Solid CopperMax. width 24"
Bright and new looking, excellent sheen and luster.

Antiqued Copper (30 gauge) Solid CopperMax. width 24"
Very rich dark finish, except over the punched area where it is highlighted.

Tin Plate (30 gauge) Tin-plated Sheet SteelMax. size 34"x48"
Closest to stainless steel in appearance.

Antiqued Tin (30 gauge) Burnished Tin-plated Sheet Steel . . .Max.size 28"x46"
Looks similar to old tin found in an old pie cupboard. Even coloration; beautifully accented with slight darkening effect around pierced areas.

Pewtertone Tin (30 gauge) Pewter in color onlyMax. size 33½"x 42"
It is the color of pewter – soft gray with a slight luster.

Pie Safe Tin (30 gauge) Tin-plated Sheet SteelMax. size 34"x 40"
It is an even-colored flat finish – no glare.

Old Zinc (30 gauge) Zinc-plated Sheet Steel (tarnished) . . .Max. size 21"x 36"
A semi-dark charcoal gray, this is a superior finish where highlighting of a pattern on the tin is desired. Beautiful appearance, suggesting great age.

Country Cupboard Tin (30 gauge) Tin-plated Sheet Steel . . .Max. size 21"x 36"
Slightly darker than tin plate, with a sign of some aging.

Vintage Tin (30 gauge) Tin-plated Sheet SteelMax. size 21"x 36"
Burnished dark finish, and even darker in punched area.

Rusted Tin* (30 gauge) Sheet SteelMax. size 28"x 35"
With slight discoloration, pitting and rusting – looks neglected and old.

* When ordering rusted tin please note that there may be occasional slight differences in the amount of rusting on any given batch. We reserve the right to make your rusted tin panels in the stock that we have at the time you place your order. Therefore, sometimes an order for rusted metal will exhibit more or less rust than another. Rusting is a naturally occurring process which we accomplish under controlled circumstances. While every attempt is made to present the "best side forward" there may be some differences or visible faults. When an order is placed for a number of rusted tin panels to be used together, every effort will be made to assure that the overall rusting will be as close as possible in shading to effect a pleasing match.

Just a sampling of our custom designs for previous customers...

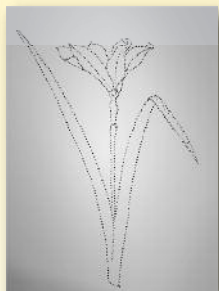

G

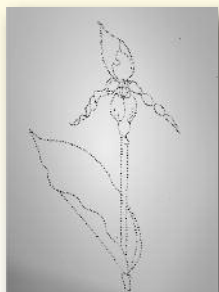

H



I

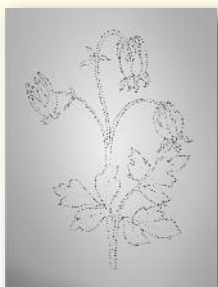

J

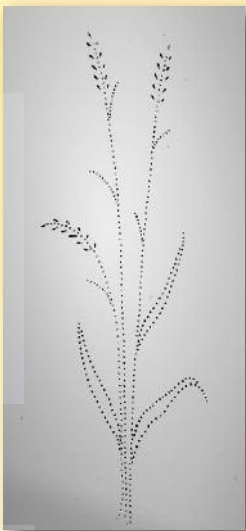

C

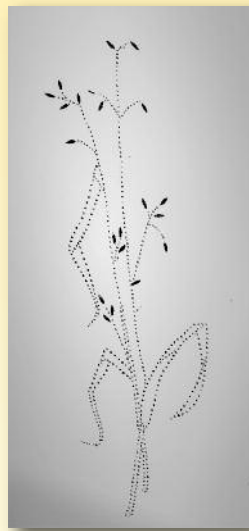

D



E



F



K



L

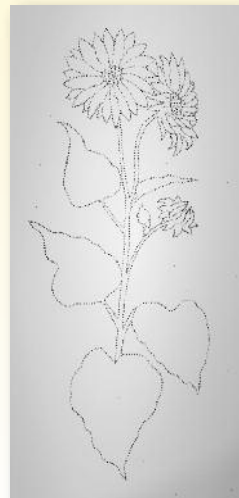

M



N

Beautiful, Timeless Finishes

Photography and printing can only show concept of choices. When in question of true color, please order a sample or two of your choice to be sure you are getting what you desire.



Brass



Antiqued Brass



Copper

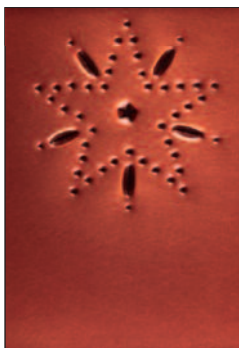

Antiqued Copper



Tin Plate

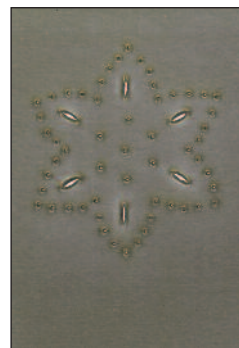

Antiqued Tin



Pewertone Tin



Pie Safe Tin



Old Zinc



Country Cupboard Tin



Vintage Tin



Rusted Tin



***Define your space
with a dramatic focal point!***

*Shown is our RP-1261, 16" x 32"
(sold unframed)*

***Mail: 615 Dunwoody Road,
Williamsport, PA 17701***

Email: sales@piercedtin.com

***Phone: 570-478-4127
(Mon-Fri 9-5 EST)***

***Fax: 570-478-2007
(24 hours a day!)***

Website: www.piercedtin.com

Pierced Tin Designs, LLC
by Country Accents